

G Battery Solar Charge MPPT controller 2 kW User Manual



Model: MPPT096020G

2023.07 Version 1.0

Copyright © 2023 ePropulsion. All Rights Reserved

Acknowledgement

Thanks for choosing ePropulsion products, your trust and support in our company are sincerely appreciated. We are dedicated to providing high-performance electric outboards, electric inboards, sup/kayak motors, reliable lithium batteries and accessories.

Welcome to visit www.epropulsion.com and contact us if you have any concerns.

Using This Manual

Before use of the product, please read this user manual thoroughly to understand the correct and safe operations. By using this product, you hereby agree that you have fully read and understood all contents of this manual. ePropulsion accepts no liability for any damage or injury caused by operations that contradict this manual.

Due to ongoing optimization of our products, ePropulsion reserves the rights of constantly adjusting the contents described in the manual. ePropulsion also reserves the intellectual property rights and industrial property rights including copyrights, patents, logos and designs, etc.

This manual is subject to update without prior notice, please visit our website www.epropulsion.com for the latest version. If you find any discrepancy between your products and this manual, or should you have any doubts concerning the product or the manual, please visit www.epropulsion.com.

ePropulsion reserves the rights of final interpretation of this manual.

This manual is multilingual, in case of any discrepancy in the interpretation of different language versions, the English version shall prevail.

Symbols

ePropulsion considers safety of great importance and recommends that anyone that comes into close contact with its products, such as those who install, operate, maintain or service ePropulsion products, exercise care, common sense and comply with the safety information in this manual and on the machine's safety decals.

The following are the relevant information marks in the user manual or the product labels:

Hazardous or warning signs indicate a potentially hazardous or hazardous situation which, if not avoided, will result in death or serious injury. Special attention and attention should be paid to the safety of you or the products involved.

Important warning:



Tips or important informations help quickly grasp the use of the product and improve efficiency. Please read and follow the instructions following the safety warning signs.



Caution:

When installing, operating, maintaining or serving ePropulsion products, there are many safety risks in the process. You need to be alert, perform relevant operations reasonably, and pay attention to safety.



Electric shock hazard:

The areas or equipment may be at risk of electric shock. The equipment uses 102.4V DC power. When operating electricity-related electrical connectors, switches, cables and other electricity-related items, power off the system to prevent electric shock.

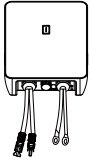

Table of Contents



Acknowledgement	1
Using This Manual	1
Symbols	1
1 Product Overview	4
1.1 Product list.....	4
1.2 Parts and Diagram.....	6
1.3 Specifications	7
1.4 Dimensions	8
1.5 Reference Table for Number of PV Modules in Series	8
1.6 Port Pin Definitions.....	9
1.6.1 6P Connector Definitions	9
1.6.2 Solar Panel Connector Definitions	10
1.6.3 Battery Connector Definitions	10
1.6.4 Temperature Cable Definitions	11
1.6.5 485essA box Definitions	12
1.6.6 CAN cable and T-Terminal Definitions.....	12
1.7 Protection.....	13
2 Installation	14
2.1 Note before Installation.....	14
2.2 Installation.....	14
3 Operation	19
4 Troubleshooting	20
5 Warranty	21
5.1 Out of Warranty	22
5.2 Limited Warranty Claim Procedures.....	23
6 Statement	24

1 Product Overview

This product can real-time detect the power generation of the solar panel and track the maximum voltage-current value to achieve the maximum power output for charging the battery. It is designed for off-grid photovoltaic systems and serves as the core control component that coordinates the operation of the solar panel, battery, and devices in off-grid photovoltaic systems.

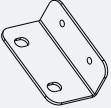
1.1 Product list

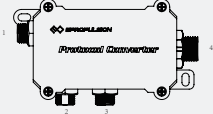
Items	Qty.	Figure	Function
MPPT controller	1		Used to coordinate the operation of solar panels and batteries, allowing solar panels to charge batteries at maximum power output
6P Connector (RJ45 Communication Terminal)	1	See Figure 1-3	Used for communication connection
Temperature Cable	1		Used for temperature data collection
Solar Panel Connector (Male and Female)	1	See Figure 1-4	Used to connect solar panels, providing power to the MPPT controller (already installed on the MPPT controller)
Battery Connector (Female)	1	See Figure 1-5	Used to connect the battery, providing power to the battery (already installed on the MPPT controller)
Mounting Bracket	2		Used to fix MPPT controller on the boat wall
M4 Countersunk Screws	4	M4X4	Used to fix the mounting bracket on the MPPT controller
Plastic Expansion Granules	4	/	Used to fix self-tapping screws

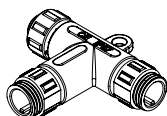
Items	Qty.	Figure	Function
M4 Self-tapping Screws	4	M5x20	Used to fix mounting bracket on the boat wall
Hexagonal Column Head Triple Combination Bolts	4	M4X22	Used to fix mounting bracket on the boat wall
Hexagonal Nuts	4	M4	Used to fix bolts
485essA box	1		Connect to 6P Connector
CAN cable	1		Connect to T-Terminal
T-Terminal	1		Connect to CAN bus
User Manual	1	/	/

1.2 Parts and Diagram

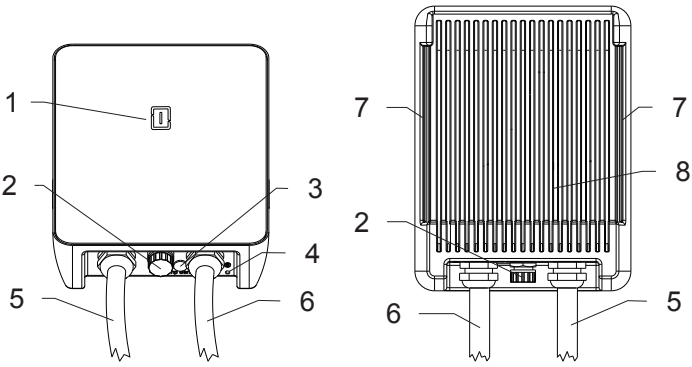

Figure 1-1

No.	Name	No.	Name
1	Indicator	6	Output Power Cable
2	RJ45 Serial Communication Interface	7	Mounting Holes for Installation Accessories
3	Temperature Sensor Line Interface	8	Heat Sink
4	Earth Connection Point	9	/
5	Input Power Cable	10	/

1.3 Specifications

Model	MPPT096020G
Electrical Parameters	
Voltage Platform	96Vdc
Output Voltage Range	72Vdc - 120Vdc
Voltage Deviation	< +/- 0.2 V
Maximum Charging Current	20 A
Photovoltaic voltage input range	140Vdc-250Vdc
Rated Input Power**	2080 W
Standby Power Consumption	< 1.8 W
Conversion Efficiency (Peak)	98%
Structural Parameters	
Product Size	290x220x90mm
Package Size	391x331x205mm
Net Weight (kg)	≈4.3
Environment	
Operating Temperature	-20°C - 55°C
Storage Temperature	-40°C - 70°C
Humidity	10%rh - 95%rh
IP Protection Level	IP65

The photovoltaic array voltage must not exceed this limit.

These power limits refer to the maximum power that the MPPT controller can handle. High power arrays can be used without damaging the MPPT controller.

1.4 Dimensions

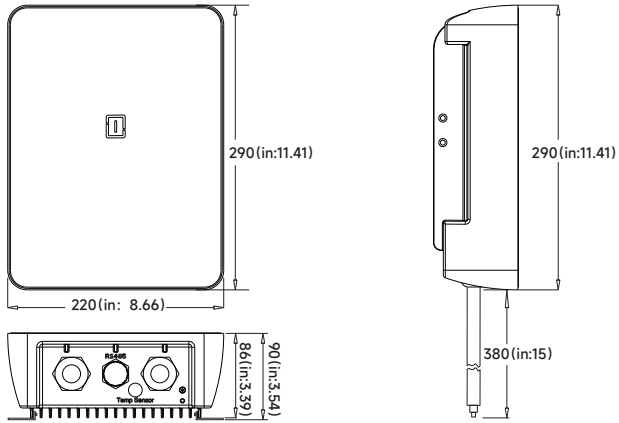

Figure 1-2

1.5 Reference Table for Number of PV Modules in Series

Voc * N = PV Input <250Vdc												
Individual PV Module Voltage Level	Voc<23V		Voc<31V		Voc<34V		Voc<38V		Voc<46V		Voc<62V	
	Max	Best	Max	Best	Max	Best	Max	Best	Max	Best	Max	Best
Number of Modules in Series N	10	9	8	7	7	6	6	5	5	4	4	3

N: N in the table represents the number of PV modules in series, and the data is for reference only.

1.6 Port Pin Definitions

1.6.1 6P Connector Definitions

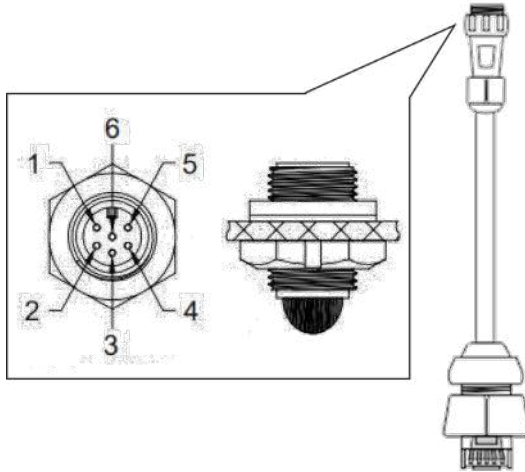

Figure 1-3

No.	Specification	Definition
1	N/A	N/A
2	22AWG	485A
3	N/A	N/A
4	22AWG	485B
5	N/A	N/A
6	N/A	N/A

Note:

Before connecting, distinguish between the network cable connector and the 6PIN connector. The network cable connector is used to connect to the MPPT controller's No.2 interface (RJ45 Serial Communication Interface), and the 6PIN connector is used to connect to the 485 interface of the MPPT controller.

1.6.2 Solar Panel Connector Definitions

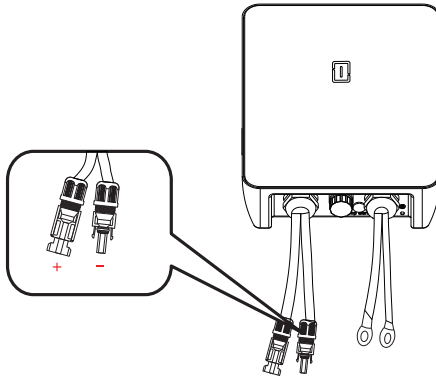

Figure 1-4

Solar Panel Terminal

No.	Specification	Definition
1	11AWG	Positive (+)
2	11AWG	Negative (-)

1.6.3 Battery Connector Definitions

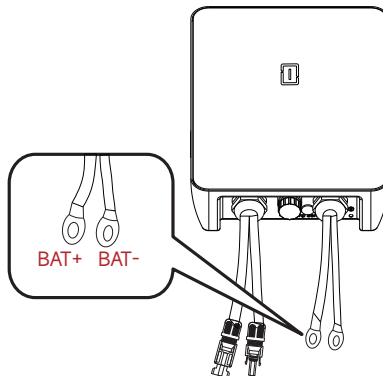

Figure 1-5

Battery Output Terminal

No.	Specification	Definition
BAT+	11AWG	Positive (+)
BAT-	11AWG	Negative (-)

1.6.4 Temperature Cable Definitions

The temperature line 's Port 2 is connected to the Temp Sensor of the MPPT controller , and Port 1 is used to collect the ambient temperature of the battery .If the battery itself has temperature detection(such as the G102 battery),this line can be optional installed.

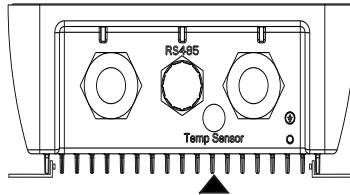

Figure 1-6

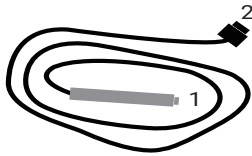

Figure 1-7

1.6.5 485essA box Definitions

The 485essA module has 4 interfaces, and interfaces 1, 2, and 3 can all be used to connect the 6P Connector, while interface 4 is connected to the A end of the CAN cable.

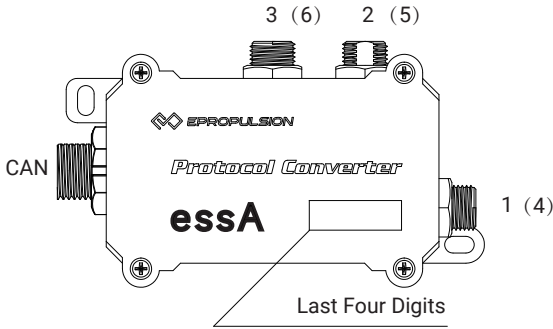

Figure 1-9

1. When installing one 485 essA box, the number of the MPPT controller is as shown in Figure 1-9;
2. When two 485 essA boxes are installed, the 485 essA box with the smaller last four digits is numbered 1 to 3, and larger last four digits is numbered 4 to 6 (in parentheses).

1.6.6 CAN cable and T-Terminal Definitions

The A end of the CAN cable is connected to interface 4 of the 485essA box (refer to Figure 1-9).

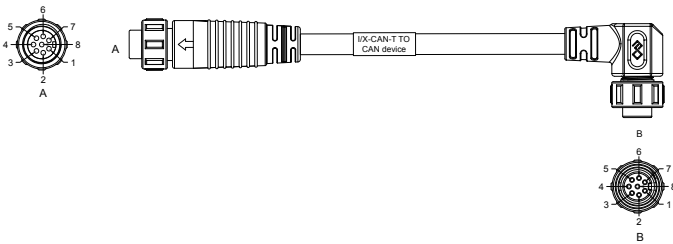

Figure 1-10

When there is only one 485essA box, interface 3 of the T-Terminal (refer to Figure 1-9) is connected to the B end of the CAN cable and interface 1 is connected to the CAN bus. When there are two or more 485essA boxes, the interface 3 and interface 1 of the two T-Terminals are connected to each other, and then connected to the B end of the CAN cable and the CAN bus.

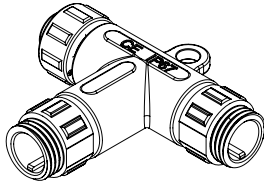

Figure 1-11

1.7 Protection

<ul style="list-style-type: none"> ✓ Reverse Connection Protection - Protects against positive and negative polarity reversal at the battery and photovoltaic array terminals. 	<ul style="list-style-type: none"> ✓ Photovoltaic Array Short Circuit Protection
<ul style="list-style-type: none"> ✓ Internal Overtemperature Protection - Reduces power operation 	<ul style="list-style-type: none"> ✓ Heatsink Temperature Limit
<ul style="list-style-type: none"> ✓ Battery Overvoltage Protection 	<ul style="list-style-type: none"> ✓ Battery Disconnection Protection

2 Installation

2.1 Note before Installation

Installation Position:

- Install the MPPT controller in a dry, well-ventilated location that allows for easy disassembly and maintenance.
- Do not install on flammable building materials; do not install on highly flammable materials; do not install in hazardous areas with explosion risks.
- Avoid exposure to harsh environments, such as high humidity, flammable and explosive areas, or places with excessive dust accumulation.
- Do not install the MPPT controller in enclosures with open or liquid-filled batteries.
- The heat sink of the MPPT controller may reach temperatures exceeding 40 °C during operation, so install the MPPT controller in a place where it is not easily touched.
- Ensure adequate ventilation when installing the MPPT controller inside an enclosure. Installing it in a sealed enclosure may cause overheating, reduced power operation, and shortened product lifespan.

Safety Information:

- Use insulated tools during installation.
- Disconnect all power sources to the MPPT controller before installing or adjusting the MPPT.
- Do not operate or install the MPPT controller alone. Please ask nearby people for assistance in case of an accident.
- The MPPT controller must be installed by qualified technicians or personnel trained in safe installation practices according to the electrical regulations of the respective country.

Proper Use:

- This MPPT controller is designed solely for solar power generation. Connecting it to any other power sources, such as wind turbines or generators, may void the warranty.
- There are no user-serviceable parts inside the MPPT. Do not disassemble or attempt to repair the MPPT controller.
- A disconnect or isolation device must be available for safely and conveniently disconnecting the MPPT from the system.

2.2 Installation

Step 1: Unpack and Check

Check the MPPT controller for any transportation damage or impact and ensure the specifications match the order.

Step 2: Check MPPT controller Parameter Limits

Ensure that, under maximum temperature compensation, the open-circuit voltage (Voc) of the solar panel array does not exceed the rated voltage of the MPPT (refer to chapter 1.5 for details). Multiple MPPT controllers can be installed in parallel on the same battery bank to obtain higher charging current. Each parallel MPPT must be connected to an independent solar panel.

Step 3: Determine Installation Space

To ensure air circulation, leave at least 15 cm (6 inches) of space above and below the MPPT controller and 10 cm (3.97 inches) on the sides. Do not install the MPPT controller inside a closed enclosure.

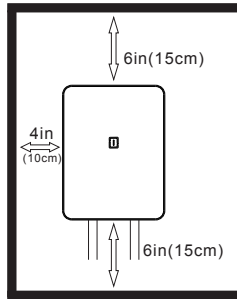

Figure 2-1

Note: The rear heat sink must be installed in a vertical direction (allowing for vertical airflow).

Step 4: Assemble and Install Mounting Bracket

Align the mounting bracket with the accessory mounting holes on the MPPT controller and secure them using M4 countersunk screws.

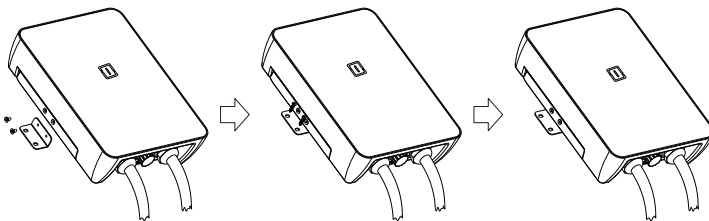

Figure 2-2

Step 5: Drill Mounting Holes on the Installation Position

Measure and mark the distance on the installation position, drill four 6mm diameter holes (if using composite material bulkheads, insert plastic expansion particles into the holes).

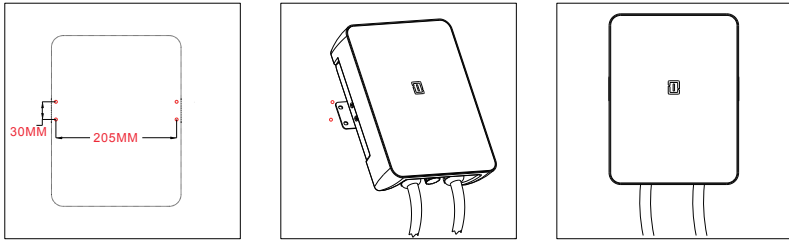

Figure 2-3

Step 6: Secure the MPPT Controller to the Installation Position

Align the MPPT controller's mounting holes with the holes created in Step 5 and secure the MPPT controller to the installation position using M4 self-tapping screws or M4 bolts, then tighten the screws.

Step 7: Connect the Cables

1. Before connecting, distinguish between input and output wires (see 1.2 Parts and Diagrams). The wire core definition is as follows: Red wire core is positive (+), and black wire core is negative (-).
2. Install a circuit breaker or fuse with a rating equal to or greater than the charging current between the cables at No. ① and ②, and keep it in the OFF state.
3. Connect the terminals at No. ③ and ④ according to the corresponding positive and negative positions (see 1.6.2 Battery Connector Definitions).
4. Connect the RJ45 communication cable and temperature sensor at No. ⑤ (see 1.6.1 6P Connector Definitions).



This MPPT controller can prevent reverse current leakage at night, so there is no need to add diodes in the system.

Avoid connecting the photovoltaic input to the MPPT controller's output power cable to prevent damage to the MPPT controller's internal circuitry and invalidate the warranty.

The installation must comply with electrical specifications. Select appropriate specifications for circuit breakers and fuses based on application requirements.

Ensure secure and stable connections, use cable clamps to secure cables to prevent movement in mobile applications, and maintain tight connections to avoid overheating due to loose connections.

There is a risk of electric shock. Before connecting, test the impedance between all terminal connections and ground.

The negative terminal of the MPPT should be connected (common negative). If necessary, ground the MPPT controller according to instructions, local specifications, and regulatory requirements.

Step 8: Power On

Before powering on, ensure all cable connections are secure.

1. Close the breaker at No. ① (Battery). If there is power in the battery, the MPPT controller will run automatically.
2. After the MPPT controller is powered on normally, close the breaker at No. ②, and the solar panels will start functioning normally.

If the MPPT controller does not start after closing the No. ① breaker, it may be due to the battery being depleted. Closing the No. ② breaker will enable the MPPT controller to be powered on properly using solar panel input.

Minimum system - Single product

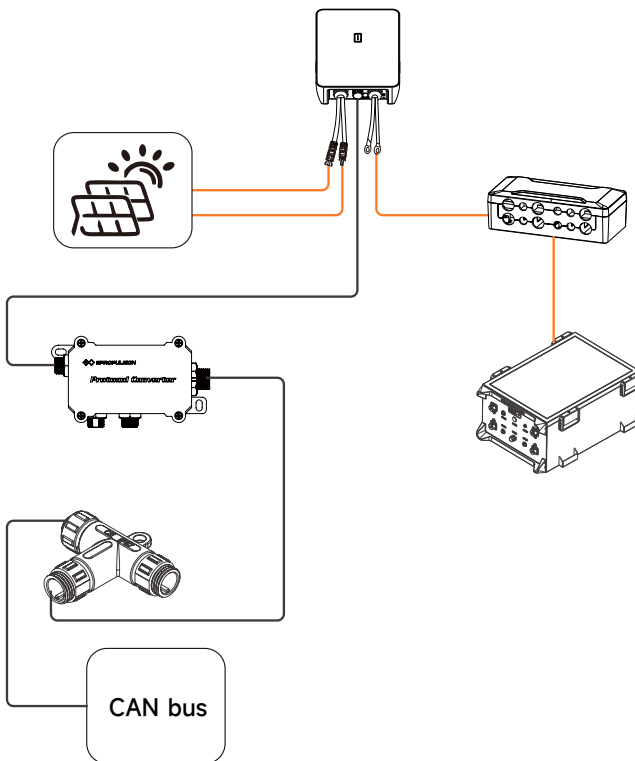

Figure 2-4

Maximum system - six products

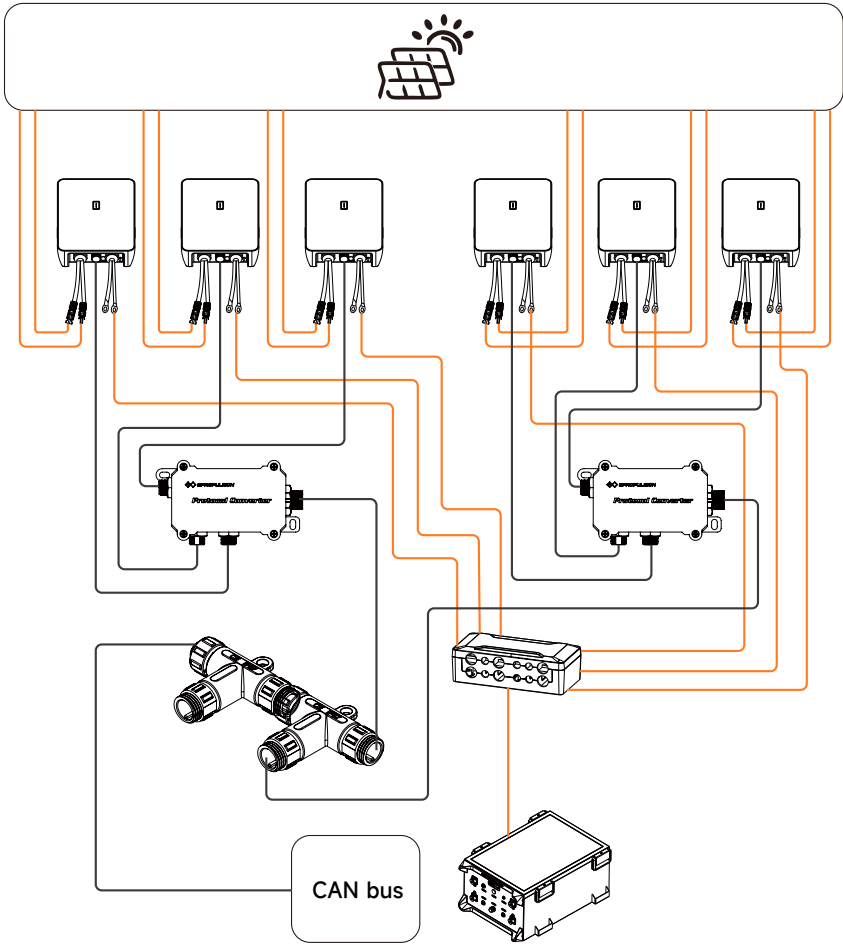

Figure 2-5

3 Operation

Scenario 1: Connecting Battery and Powering On

Indicator Light Color	Indicator Light Status	MPPT controller Status
Yellow	Flash	1. Bat not under-voltage, PV under-voltage or PV not connected, Standby 2. Bat under-voltage, and PV under-voltage or PV not connected (CO), Standby
Red	Steady On	Battery over-voltage, PV under-voltage, or PV not connected (CO)
/	No Light	Battery Depleted

Scenario 2: PV Connected and Powering On without Battery (Activated once every 1 minute, 6S each time)

Indicator Light Color	Indicator Light Status	MPPT controller Status
Red	Steady On	PV Over-voltage (Above 250V ± 2V), Alarm
Yellow	Flash	PV Normal/Over-voltage Recovery (140Vdc-245Vdc), Standby
/	No Light	PV Module Fault or Circuit Fault

Scenario 3: Connecting Battery and PV and Powering On

Indicator Light Color	Indicator Light Status	MPPT controller Status
Green	Flash	1. Battery under-voltage charging, PV normal charging (140Vdc-245Vdc) 2. Other charging status
	Steady On	CV state normal charging
Red	Steady On	APP On/Off Control - Remote Shutdown
Yellow	Flash	After lithium battery low-voltage protection, PV normal (140Vdc-245Vdc)

4 Troubleshooting

1. The status indicator light is not lit, and the MPPT controller have no power.

Troubleshooting:

Use a multimeter to check the voltage at the MPPT terminals. The battery voltage must be 10Vdc or higher. If no voltage is measured, check the connections, fuses, and circuit breakers.

2. The MPPT controller is not charging.

Troubleshooting:

Check the fuses, circuit breakers, and connections. Use a multimeter to check the voltage at the MPPT terminals. Before starting the charging, the input voltage must be greater than the battery voltage.

3. The battery is in a long-term low battery or depleted state.

Troubleshooting:

- 1.The solar panels are insufficient to generate enough energy to meet system use. Consider increasing the solar panel array appropriately.
- 2.The battery capacity is too small to store enough energy to meet system use. Consider increasing the battery capacity of the battery bank.

The input and output are not electrically isolated, and dangerous solar voltage may be present. Under certain fault conditions, the battery may be overcharged. Take protective insulation measures before contact.

These disconnect devices must be included in the fixed wiring. Before disconnecting the MPPT controller's connections, make sure to disconnect all power sources.

5 Warranty

Guangdong ePropulsion Technology Co., Ltd. (“ePropulsion”), China, warrants its products to be free of defects in material and workmanship under normal usage with proper installation and routine maintenance for a period of twenty-four (24) months from date of delivery of products to end customers (the “Limited Warranty Period”), the I series motor and G battery will have another extend 36 months warranty period after registration on the official website. The Limited Warranty is provided to the first end customer of ePropulsion products ONLY. The Customer is entitled to free repair or replacement of defective or non-conform parts. Any warranty claim must be made within six (6) months of discovery of issues as provided below.

If the Limited Warranty Period expires, you can still enjoy maintenance services from dealers/distributors authorized by ePropulsion (the “ePropulsion Service Partners”) with minimum maintenance charge per occurrence.



In all warranty cases, ePropulsion will only bear the repair cost and other costs (such as those related to product installation, disassemble, transportation, financing, rental, etc.) as a direct result for of issues covered by the Limited Warranty only. Any costs irrelevant to or out of the scope of the Limited Warranty will be born by the Customer alone., which shall NOT include costs irrelevant such as those related to product installation, disassemble, transportation, financing, rental, etc.

Beyond the Limited Warranty, the Customer may have statutory rights in your jurisdiction according to applicable laws. Nothing in this Limited Warranty affects such rights. The Customer may have warranty claim rights arising from the purchase contract with ePropulsion Service Partners in addition to the rights granted by this Limited Warranty.

Products for commercial/professional use, even if only temporarily, are not covered by the Limited Warranty. Instead, the statutory warranty in your jurisdiction shall apply. You are encouraged to consult with ePropulsion Service Partners for applicable warranty and advice before engaging in such use.

*** Commercial/professional Use refers to application cases that have high use frequency, high-reliability requirement or aim for money making, etc.**

To keep your warranty valid, you shall follow:

-  Keep the product label intact and record the Serial Number shown on the label. Never tear the label off the product. A product without the original product label is not covered by the Limited Warranty provided by ePropulsion;
-  The Limited Warranty is not transferable and will not be reissued;
-  The Limited Warranty may change from time to time. Pls visit our website (<http://www.epropulsion.com>) for the latest version.

5.1 Out of Warranty

ePropulsion may refuse a warranty claim if:

- Any improper operation contradicts what is written in the user manual;
- Accident, misuse, dropping, improper care or storage, willful abuse, physical damage, overcharging, over discharging, or unauthorized repair;
- Water ingress caused by external sources such as fishing nets, submerging underwater, etc;
- Product modification, alternation, disassembly, or parts/accessories attachment, which are not expressly permitted or recommended by ePropulsion;
- Failure of, or damage caused by, any 3rd party products;
- Repositioning of the high-voltage batteries in the boat;
- The battery incorrectly charging, overcharging, over-discharging, operating in temp out of scope described in the user manual;
- Consumables are out of warranty scope (like propeller, anode...etc.);
- Purchases of product from unauthorized dealers or seller;
- Normal wear and tear and routine servicing are excluded from the warranty;
- The product gets further damaged due to improper packing during delivery. The further damaged part will be deemed as out of warranty coverage;
- Lithium battery is classified as a UN9 hazardous item, posting and packing must be in accordance with the relevant law of the local country directive. Non-compliance may result in out of warranty coverage.

5.2 Limited Warranty Claim Procedures

The Customer shall follow the warranty claim process to make a Limited Warranty claim:

1. Contact your nearest ePropulsion Service Partners and they will provide further instruction to you if such defects are covered by the Limited Warranty or theirs.
2. Send the defective product to them together with Proof of 1(st)-time Purchase (e.g., receipt, invoice, etc., with information of product purchased and date of purchase), the Confirmation of Online Warranty Registration, ex-factory Serial Number, etc. Note that all labels shall be kept intact. The warranty is valid only when the information above is correct, genuine, and complete;
3. Make sure the product is properly packed during delivery, the original package is highly recommended.
4. The ePropulsion Service Partners will conduct diagnosis and examination on the defective products to check the validity of the warranty claim.
5. If your warranty claim is accepted, the Product or its defective components/parts will be either repaired or replaced free of charge. Note that any delivery cost incurred in the process shall be bearded by you.
6. In case your warranty claim be rejected, a repair/replace cost and fee with round trip delivery cost will be estimated and sent to you for confirmation. ePropulsion Service Partners will only begin the work after your written confirmation.

6 Statement

Operation is subject to the following three conditions:

- (1) This device may not cause harmful interference, and
- (2) this device must accept any interference received, including interference that may cause undesired operation.

Note:

This equipment has been tested and found to comply with the limits for a Class B digital device, pursuant to part 15 of the FCC Rules. These limits are designed to provide reasonable protection against harmful interference in a residential installation. This equipment generates, uses and can radiate radio frequency energy and, if not installed and used in accordance with the instructions, may cause harmful interference to radio communications. However, there is no guarantee that interference will not occur in a particular installation. If this equipment does cause harmful interference to radio or television reception, which can be determined by turning the equipment off and on, the user is encouraged to try to correct the interference by one or more of the following measures:

- Reorient or relocate the receiving antenna.
- Increase the separation between the equipment and receiver.
- Connect the equipment into an outlet on a circuit different from that to which the receiver is connected.
- Consult the dealer or an experienced radio/TV technician for help.

Correct Disposal of this product:

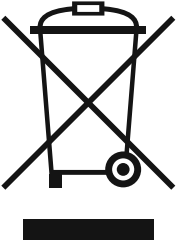

This marking indicates that this product should not be disposed with other household wastes throughout the EU. To prevent possible harm to the environment or human health from uncontrolled waste disposal, recycle it responsibly to promote the sustainable reuse of material resources. To return your used device, please use the return and collection systems or contact the retailer where the product was purchased. They can take this product for environmental safe recycling.

Declaration of conformity

We Guangdong ePropulsion Technology Limited, hereby, declares that this equipment is in compliance with the applicable Directives and European Norms, and amendments.

Object of the Declaration:Product:

Product:G Battery MPPT Solar Charger Controller 2kW

Model: MPPT096020G

The object of the declaration is in conformity with the following directives:

Electromagnetic Compatibility (EMC)	2014/30/EU
DirectiveLow Voltage Directive (LVD)	2014/35/EU
RoHS 2 Directive(RoHS)	2011/65/EU &2015/863/EU

Applied Standards:

EN 61000-3-11:2000
EN 61000-3-12:2011
EN IEC 61000-6-2:2019
EN IEC 61000-6-4:2019
EN 62109-1: 2010
EN 62109-2: 2011
IEC 62321-5:2013
IEC 62321-4:2013+AID1:2017
IEC 62321-7-1:2015
IEC 62321-7-2-2017
IEC 62321-6:2015
IEC 62321-8:2017

EC REP

Name: REP Europe GmbH

Address: Werner-von-Siemens-Str. 264319 Pfungstadt Germany

Phone: +49 157 51253212

info@rep-europe.de

Manufacturer

Name: Guangdong ePropulsion Technology Limited

Address: Room 801, Building 1, 11 Daxue Road, Songshan Lake, Dongguan, Guangdong Province, China

Signature: 

Date: 30th, August, 2023

Shizheng Tao, Chief Executive Officer & Cofounder of
Guangdong ePropulsion Technology Limited

WARRANTY CARD

(*In order to validate warranty, please fill in this form first and read the Warranty Policies.)

|| OWNER INFO. ||

Owner Name			
Address			
Phone		Email	

|| DEALER INFO. ||

Store Name			
Address			
Phone		Email	

|| PRODUCT INFO. ||

Date of Purchase (mm/dd/yyyy)	
Serial No.	



Thanks for reading this user manual.

If you have any concerns or find any problems while reading, please don't hesitate to contact us. We are delighted to offer service for you.

Guangdong ePropulsion Technology Limited

Webseite: www.epropulsion.com

E-Mail: service@epropulsion.com