



SPIRIT 1.0 Evo User Manual Bedienungsanleitung SPIRIT 1.0 Evo

2023.05 Version 1.4

Copyright © 2021-2023 ePropulsion. All Rights Reserved

Acknowledgement

Thanks for choosing ePropulsion products, your trust and support in our company are sincerely appreciated. We are dedicated to providing high-performance electric outboards, electric outboards, sup/kayak motors, reliable lithium batteries and accessories.

Welcome to visit www.epropulsion.com and contact us if you have any concerns.

Using This Manual

Before use of the product, please read this user manual thoroughly to understand the correct and safe operations. By using this product, you hereby agree that you have fully read and understood all contents of this manual. ePropulsion accepts no liability for any damage or injury caused by operations that contradict this manual.

Due to ongoing optimization of our products, ePropulsion reserves the rights of constantly adjusting the contents described in the manual. ePropulsion also reserves the intellectual property rights and industrial property rights including copyrights, patents, logos and designs, etc.

This manual is subject to update without prior notice, please visit our website www.epropulsion.com for the latest version. If you find any discrepancy between your products and this manual, or should you have any doubts concerning the product or the manual, please visit www.epropulsion.com.

ePropulsion reserves the rights of final interpretation of this manual.

This manual is multilingual, in case of any discrepancy in the interpretation of different language versions, the English version shall prevail.

Symbols

The following symbols will help to acquire some key information.



Important instructions or warnings



Useful information or tips

Product Identification

Below picture indicates the serial numbers of SPIRIT 1.0 Evo. Please note the position of the serial numbers and record them for access to warranty service and other after-sale services.

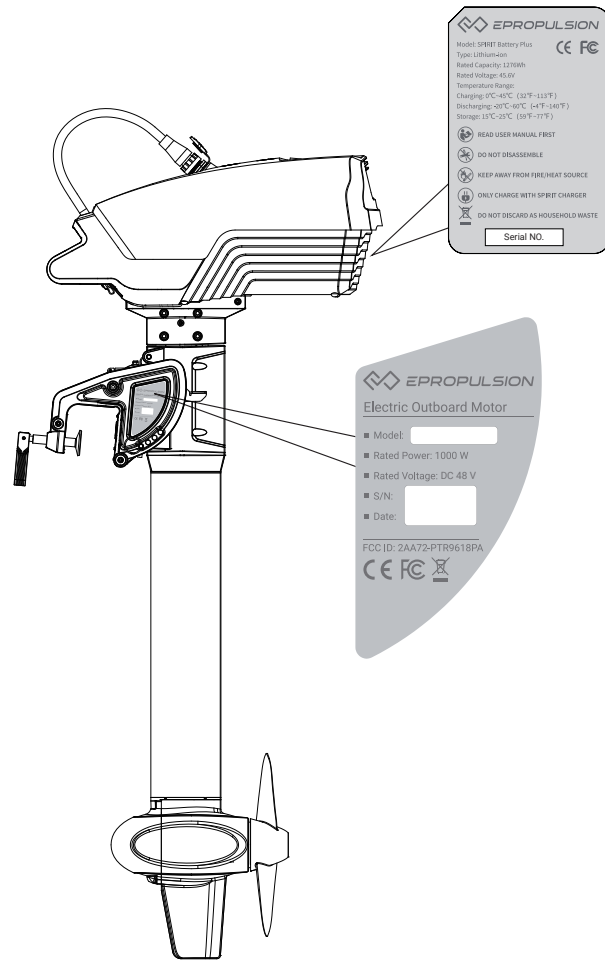

Figure 0-1

Table of Contents

Acknowledgement	1
Using This Manual	1
Symbols	1
Product Identification	2
1 Product Overview	5
1.1 In the Package	5
1.2 Parts and Diagram.....	7
1.3 Specifications	8
1.4 Declaration of Conformity.....	10
2 Important Notes before Start	12
2.1 Outboard	12
2.2 Battery	13
3 Installation	15
4 Connecting 48V Battery	19
4.1 Selecting the Battery	19
4.2 Connecting 48V Battery for Single Engine.....	19
4.3 Connecting 48V Battery for Twin Engine	21
5 Operation	22
5.1 Checklist before Start	22
5.2 Starting.....	22
5.3 Stopping	24
5.4 Power off the External Battery.....	25
5.5 Tiller Adjustment	26
5.6 Tilting up the Outboard Motor	28
5.7 Fixing the Steering Direction.....	29
5.8 Fixing for Easy Carrying	29
6 Evo Control System	30
6.1 Display Panel	30
6.2 Charging the Remote Control	34
6.2.1 Charging by Solar Power	34

6.2.2 Charging by Wired Connection	34
6.3 Power Adjusting	36
6.3.1 Power Adjusting for Evo Control System	36
6.3.2 Recalibration	37
6.4 Use of Safety Wristband	38
6.4.1 Pairing Safety Wristband with Evo Control System	38
6.4.2 Man Overboard Protection	38
6.4.3 Emergency Stop	38
6.5 Pairing Evo Control System with the Outboard	39
6.6 Hydro Generation Function	41
6.7 Warning Messages	42
7 Battery Charging	44
8 Trim Angle Adjusting	46
9 Anti-grounding Mode	48
10 Maintenance	50
10.1 Notes	50
10.2 Propeller Maintenance	50
10.3 Replacing the Anode	51
10.4 Maintenance of Electrical Contacts	52
10.5 Maintenance Time Table	53
11 Transportation and Storage	54
11.1 Transportation	54
11.2 Placement	55
11.3 Storage	55
11.4 Disposal and environment	55
12 Emergency Situations	56
12.1 Impact Damage	56
12.2 Submerged Outboard	56
12.3 Low Battery Level	56
13 Warranty	57
Out of Warranty	58
Limited Warranty Claim Procedures	58

1 Product Overview



SPIRIT 1.0 Evo is designed to be an integrated electric outboard with high overall efficiency and long cruising duration. The power of SPIRIT 1.0 Evo is equivalent to a 3hp petrol outboard but works quieter. With removable tiller or remote control, it's easy to carry and store. All these high-performance features make SPIRIT 1.0 Evo an ideal option for tenders, dinghies and sailboats.

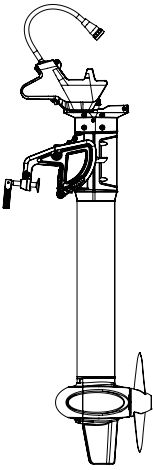
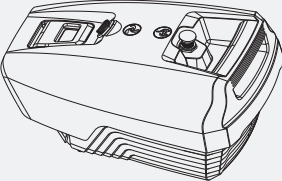

The SPIRIT 1.0 Evo includes two models, SPIRIT 1.0 Evo-L and SPIRIT 1.0 Evo-S, which have different shaft lengths for adaptation of different transom heights.

1.1 In the Package

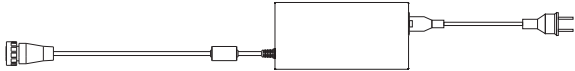
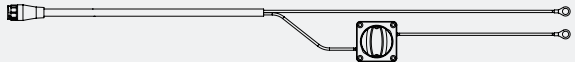
Unpack the package and check if there is any damage caused during transport. Check all the items inside the package against the below list. If there is any transport damage or lack of any listed item, please contact your dealer immediately.

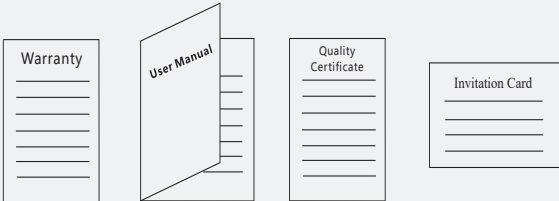
Items	Qty./Unit	Figure
Outboard (Main part)	1 set	
Battery (Purchase Separately)	1 set	

Items	Qty./Unit	Figure
Battery Charger	1 set	
Spirit External Battery Cable (Purchase Separately)	1 set	
Steering Lock Pin	2 pieces	
User Manual, Warranty Card, Quality Certificate & Invitation Card	1 set	

-  Save the ePropulsion original package for the outboard storage.
-  Other accessories mentioned in this user manual need to be purchased by users from ePropulsion authorized dealers.
-  There are currently four types of official chargers for SPIRIT Battery Plus. The one included in the package is Standard Charger. The other three are Fast Charger, Solar Charger and DC Charger, which need to be purchased separately by users from ePropulsion authorized dealers.

1.2 Parts and Diagram

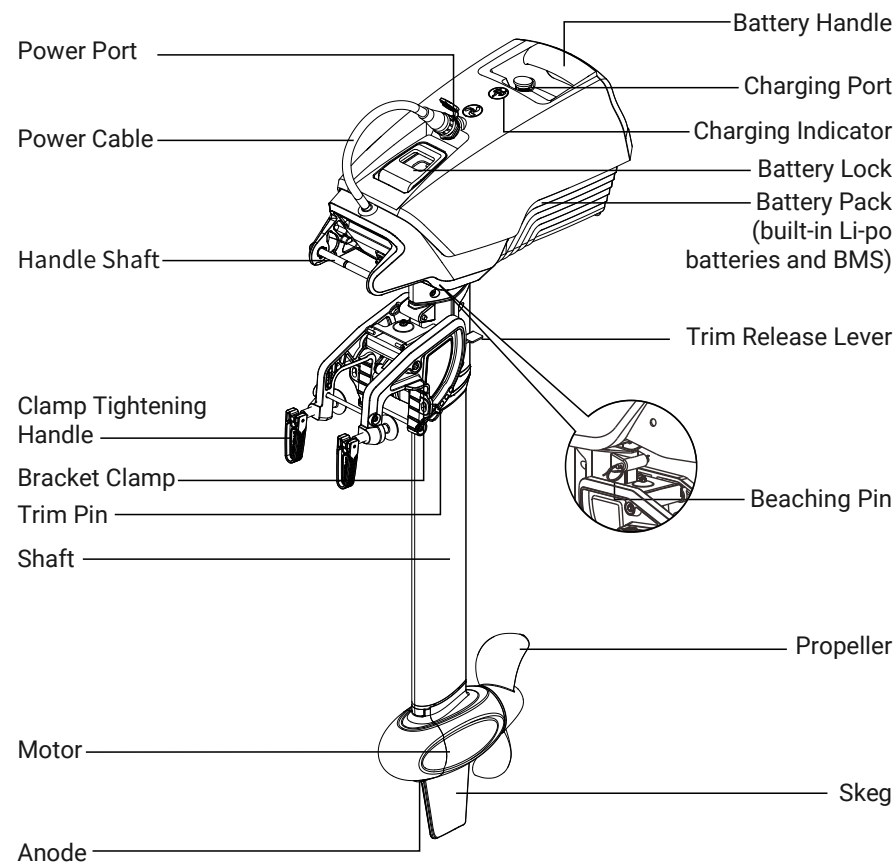

Figure 1-1

1.3 Specifications

SPIRIT 1.0 Evo-L / SPIRIT 1.0 Evo-S	
Type	Electric Outboard Motor
Input Power	1 kW
Equivalent Power	3 hp
Max Overall Efficiency	55%
Rated Rotation Speed	1200 rpm
Control System	Evo Remote Control / Evo Tiller / Evo Side Mount Control / Evo Dual Remote Control
Motor Weight*	10.2 kg / 22.5 lbs (S) 10.6 kg / 23.4 lbs (L)
Dimension (L×W×H)*	550 × 457 × 1150 mm / 21.7 × 18 × 45.3 inches 550 × 457 × 1275 mm / 21.7 × 18 × 50.2 inches
Shaft Length	625 mm / 24.6 inches (S) 750 mm / 29.5 inches(L)
Trim Angles	manual, 0°, 7°, 14°, 21°
Tilt Angle	manual, 85°
Propeller (Diameter × Pitch)	11" × 5.8" 2-blade composite propeller

*The weight only includes the motor body, excluding battery, control and remote kit.

*The dimensions only refers to a SPIRIT 1.0 Evo motor without the tiller installed.

SPIRIT Battery Plus	
Chemistry	Lithium-ion polymer battery
Capacity	1276 Wh / 28 Ah
Rated Voltage	45.6 V
Cut-off Voltage	33.6 V
Full Charged Voltage	52.2 V
Charging Time	Standard charger: 8.5 Hrs Fast charger: 3.5 Hrs
Battery Life	500 cycles at 80% DOD
Dimension (L×W×H)	416 × 275 × 202 mm 16.4 × 10.8 × 8 inches
Weight	8.7 kg / 19.2 lbs
Recommended Charging Temperature	0°C to 45°C (32°F to 113°F)
Recommended Discharging Temperature	-10°C to 45°C (14°F to 113°F)

External Battery Requirement	
Type	Lead-acid Battery or Lithium Battery
Rated Voltage	48 V
Minimum Voltage	39 V
Maximum Voltage	60 V
Minimum Continuous Discharge Current	28 A
Internal Resistance	<100 mΩ

SPIRIT 1.0 Plus Charger	
Output Power	180 W
Output Voltage	52.2 V DC
Output Current	3.5 A
Cut-off Current	0.4 A
Temperature Range	Operation: -10°C ~ 45°C (14°F ~ 113°F) Storage: -30°C ~ 70°C (-22°F ~ 158°F)
Rated Input Voltage	100 ~ 264 V AC
Output Frequency	50 Hz / 60 Hz
Input Current (Max)	2 A @ 220 V
Efficiency	≥87%

! It is forbidden to charge other batteries with SPIRIT charger. It is strictly forbidden to charge SPIRIT battery with non-official standard charger.

! SPIRIT Battery Plus, SPIRIT 1.0 Evo machine and SPIRIT 1.0 Plus charger should be used together. It is forbidden to use SPIRIT Battery Plus and SPIRIT 1.0 Plus charger for SPIRIT 1.0 machine, and it is forbidden to use SPIRIT battery for SPIRIT 1.0 Evo machine. Otherwise, the consequences of mixed use are at your charge.

1.4 Declaration of Conformity

We Guangdong ePropulsion Technology Co., Ltd., hereby, declares that this equipment is in compliance with the applicable Directives and European Norms, and amendments. The full text of the EU declaration of conformity is available at the following internet address: <http://yachter123.com/sy>

Object of the Declaration:

Product: Electric Outboard Motor

Model: SPIRIT 1.0 Evo, SPIRIT 1.0 Evo-S, SPIRIT 1.0 Evo-L



The object of the declaration is in conformity with the following directives:

Electromagnetic Compatibility (EMC) Directive	2014/30/EU
Machinery Directive	2006/42/EC
Radio Equipment Directive	2014/53/EU

Applied Standards:

EN 55014-1:2017	EN 300328:2019
EN 55014-2:2015	EN 50663:2017
EN 61000-3-2:2014	EN 62368-1:2014+A1:2017
EN 61000-3-3:2013/A1:2019	EN 60204-1:2018
EN 301489-1:2019	EN ISO 12100:2010
EN 301489-3:2019	

This device complies with part 15 of the FCC Rules: Operation is subject to the following two conditions:

1. This device may not cause harmful interference and,
2. This device must accept any interference received, including interference that may cause undesired operation.

EC REP

Name: REP Europe GmbH

Address: Werner-von-Siemens-Str. 264319 Pfungstadt

Phone: +49 157 51253212

Manufacturer

Name: Guangdong ePropulsion Technology Limited

Address: Room 801, Building 1, 11 Daxue Road, Songshan Lake, Dongguan, Guangdong Province, China

Signature: 陶师正

Date: 26th of May, 2023

Shizheng Tao, Chief Executive Officer & Cofounder of

Guangdong ePropulsion Technology Limited

2 Important Notes before Start

The SPIRIT 1.0 Evo electric outboard motor is designed to offer clean propulsion and excellent experience on water. For safety reasons, please read the following instructions and notes before using this product. By using this product you hereby: 1) agree to these notes and instructions; 2) agree not to use this product for purposes that infringe upon or contravene laws and regulations; 3) agree to be responsible for your own conduct while operating this product.

2.1 Outboard



WARNING

- Only allow adults who have thorough understanding of this manual to operate this product.
- Always have a paddle on board especially if the electric outboard motor is the only propulsion system.
- Familiarize yourself with all the outboard operations, including start/stop, steering and tilting.
- Check the status of the outboard and battery level before each trip.
- Follow the boat manufacturer's instructions on the maximum allowed outboard power of your boat, do not overload the boat or the outboard.
- Take seriousness of battery safety. Follow battery instructions, avoid short-circuit, overheat, overcharge and over-discharge.
- Only run the outboard while the propeller is under water.
- Stop the outboard immediately if someone falls overboard.
- Do not leave the outboard in the water while the boat speed reach 35km/h.
- Tilt up the outboard above water after use.
- Wash the outboard with fresh water after operating in salt water.
- If an error code displays and the outboard malfunctions, please reset the throttle to zero position and cut the power off, then refer to 6.7 Warranty Messages to acquire the solution to the error.
- For protection considerations, the motor will stop immediately if the battery voltage drops below the critical level during operation or when running.

- To keep electric connectors in good condition, please spray the connectors about every 3 months with contact spray.
- To store the outboard motor, put the machine in original ePropulsion package and keep it in a dry and ventilated place without direct sun exposure.
- If the communication cable is not connected, ensure to cover the cap of the communication connector on the machine, otherwise the connector will corrode and the machine will not be able to communicate.
- This product is not a toy. Please keep them out of the reach of children.
- Product information and certification marks are located in the electric outboard motor.

2.2 Battery

The SPIRIT Battery Plus specially designed for SPIRIT 1.0 Evo can only be charged with an ePropulsion original charger. The battery has a built-in battery management system which provides cell balancing function, over charging protection, over discharging protection, short-circuit protection, over temperature protection, under temperature protection, over current protection, communication function, etc. Though the battery has been tested to be reliable and safe during normal operation, it should be handled with care as safety is critically important. Please adhere to the following instructions when using it.



WARNING

- Do not drop, strike or squash the battery.
- Do not disassemble the battery or conduct unauthorized repair, the battery disassembly can only be conducted by ePropulsion service.
- Never charge a broken or damaged battery.
- Only charge the battery with an ePropulsion original charger.
- Do not charge the battery near flammable materials like carpet or wood.
- Disconnect charger when not in use.
- Though the battery is IP67 waterproof, it's suggested not to immerse it in water or store it in moist environment.
- Keep conductive objects away from the discharging port and charging port to avoid damage of electronic components.
- Use the port cap to avoid accidental short-circuit.

- Never discharge the battery below 33V. Store the battery in dry environment.
- Charge the battery immediately after full discharge.
- Before long time storage, ensure the battery charge level is 60% around, store the battery in 15°C ~ 25°C (59°F ~ 77°F) ambient temperature. If the battery level is larger than 60% for more than ten days without activity, the battery itself will discharge with a small current around 100mA until it reaches the 60% battery level.
- Battery will actively discharge to 75% after 20 days without charging or discharging.
- If battery level is low for a long time, it will enter sleep mode. Charge to wake it up.
- During long time storage, activate the battery every 3 months by a charge condition and keep the battery charge level at 60% around. This activation is very important and it can help to keep the battery in good condition.
- After long time storage, fully charge the battery before use.
- Do not leave the battery in a hot or pressurized container, such as trunk of the vehicle on hot days.
- Dispose of unusable or damaged batteries in a container specially reserved for this purpose, follow appropriate local guideline and regulations. For further information you can contact your local solid waste collecting point or your dealer.
- Never dispose the battery as general household waste or in fire.
- Do not attempt to disassemble, repair or modify the product, as this may cause fire or even completely damage the product.
- Do not disassemble, puncture or crush the product nor expose it to fire. Disposal of a battery into fire or a hot oven or water or other liquids or mechanically crushing or cutting of a battery, that can result in an explosion.
- Leaving a battery in an extremely high temperature surrounding environment that can result in an explosion or the leakage of flammable liquid or gas.
- A battery subjected to extremely low air pressure that may result in an explosion or the leakage of flammable liquid or gas.
- Replacement of a battery with an incorrect type that can defeat a safeguard (such as catching fire, explosion, leakage of corrosive electrolyte etc).

3 Installation

Step1: Hang the motor on the transom and tighten the two clamp handles.

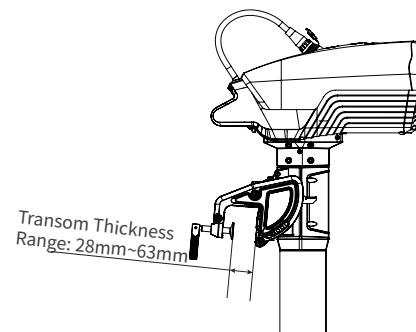

Figure 3-1

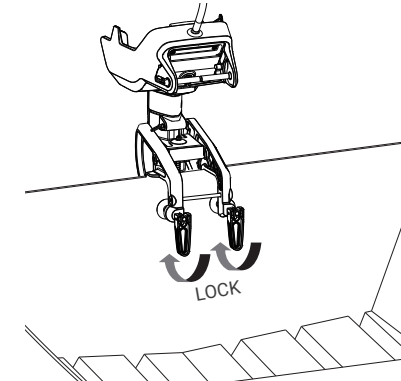

Figure 3-2

After tightening the clamp handles fully, the users can also use two screws to fix the outboard to the boat. The dimensions of the two mounting holes are shown below.

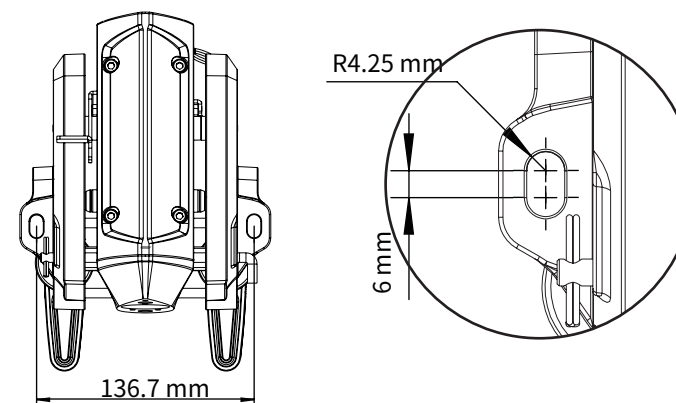

Figure 3-3

💡 Never use screws to fix the outboard when the clamp handles are not fully tightened.

💡 Ensure the outboard is firmly fixed as loosened clamp screws may cause the outboard to fall into water or get damaged. Check the screws or clamps every time before use since they may be loosened because of mechanical vibrations.

💡 A cable is recommended to be used to avoid complete loss of your outboard in case it falls off the transom. Use the cable to connect your outboard and a secure mounting point on the boat.

💡 For single-engine boat, ensure to mount the outboard on the center line of your boat. For twin-engine boat, ensure to mount the outboards equidistant from the center line and the minimum space between outboards is 840mm. If the boat shape is asymmetric, please consult your dealer to get proper solution.

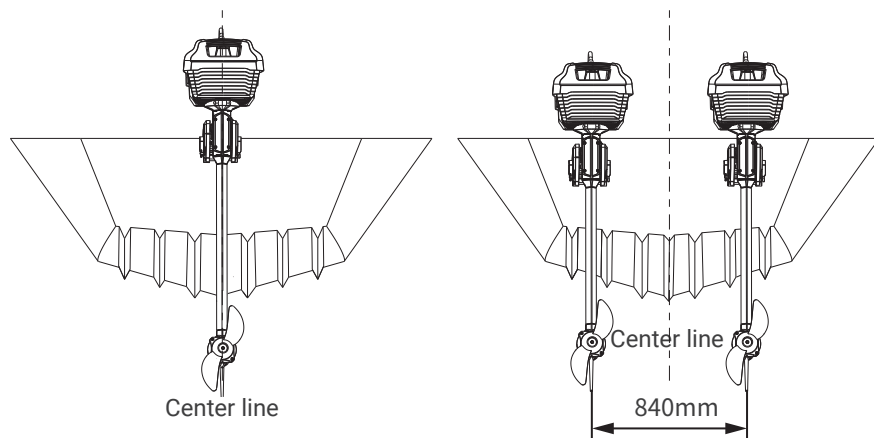

Figure 3-4

The mounting height of the outboard affects the running speed seriously. When the mounting height is too high, ventilation may occur to waste power. When the mounting height is too low, the water resistance will increase and it will lead to efficiency and running speed reducing.

Transom Height	Recommended Model
400mm~500mm	SPIRIT 1.0 Evo-S
Higher than 500mm	SPIRIT 1.0 Evo-L

Select a proper model according to your transom height and applications. The optimum mounting height is affected by the conditions of boat and requirements. It's recommended to test running at a different height to help obtain the optimum mounting height. You can consult your dealer to get more information.

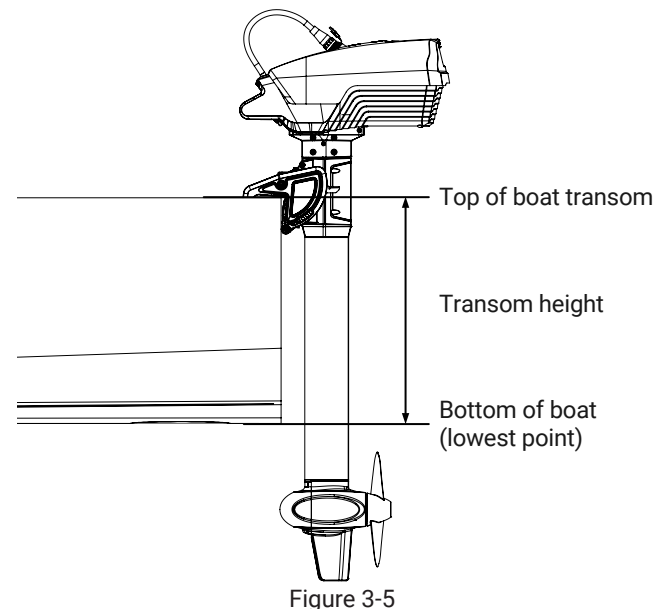

Figure 3-5

Step2: Install Evo Control System. Please refer Evo Control System Installation Guide, mount the Evo Remote Control/Evo Tiller on the boat/outboard, and complete the wiring between Evo Control System and outboard.

Step3: Lift the battery by gripping the handle and pull up the battery lock. Align the two slots on the battery bottom to the blocks on the bracket and put down the battery. Release the battery lock and lock the battery on the bracket.

💡 Ensure to hold the battery handle before detaching or mounting the battery.

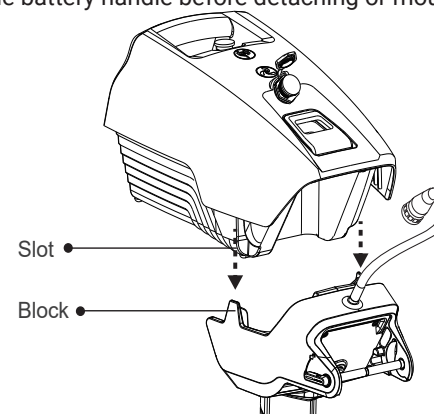

Figure 3-6

Step4: Plug the power cable connector in the power port and tighten the connector. The connector is metal, and its own needs to be figure tight $\frac{1}{2}$ of a turn clockwise.

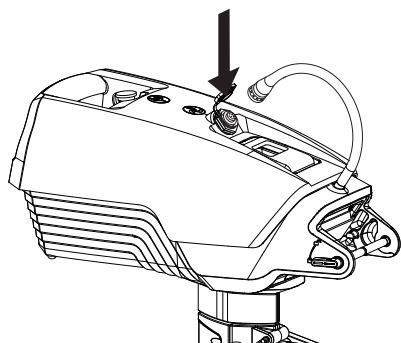

Figure 3-7

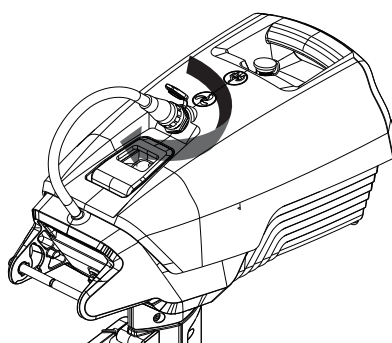



Figure 3-8

 Make sure the power cable connector and socket are dry before connecting to avoid short-circuit.

 Please spray and clean the connectors about every 3 months with contact spray.

4 Connecting 48V Battery

4.1 Selecting the Battery

Lithium-based and lead-acid batteries can be used to supply power for SPIRIT 1.0 Evo. Considering the high performance in energy density and discharge ability, lithium-based batteries are more preferable. To ensure that SPIRIT 1.0 Evo can work at its full power continually, the battery must have a continuous discharge capacity of 1000W. To ensure at least one hour of duration, the battery capacity should reach 1000Wh or above.

 When using ePropulsion Batteries, the batteries will work well once being correctly connected. When using non-ePropulsion batteries, before starting the outboard, users should configure the batteries via the Evo control system for the first time use, otherwise the batteries may not work properly.

 Only use the same batteries (same model, same capacity, same age and same manufacturer) in series or in parallel configuration. Variations in the batteries will cause damage to them.

4.2 Connecting 48V Battery for Single Engine

1. Make sure the power switch is off before connection.
2. First connect the external battery cable to the battery.
3. Connect the external battery cable with the power cables from the outboard.
4. If using ePropulsion battery (not SPIRIT Battery) and connecting to the Evo remote control wirelessly, connect the battery to the outboard with a communication cable. If using ePropulsion battery (not SPIRIT Battery) and connecting to the Evo control system wiredly, connect the battery and Evo control system to the outboard with a y type communication cable and two communication cables.



Figure 4-1

- ⚠️ Avoid battery short-circuit during connection.
- ⚠️ Do not short-circuit the main switch with other power supplies. The main switch should be mounted on the boat, and the back plate of the main switch should not be removed.
- ⚠️ Outboard motor will stop working once the power cable disconnects.
- 💡 Counterclockwise turn the reset button on the power switch until it is stuck to power on the battery before use.
- 💡 Users can also enlarge the battery capacity by connecting multiple batteries in parallel.
- 💡 During use, if a poor contact is found, it is recommended to check the tightening of each terminal connection.

4.3 Connecting 48V Battery for Twin Engine

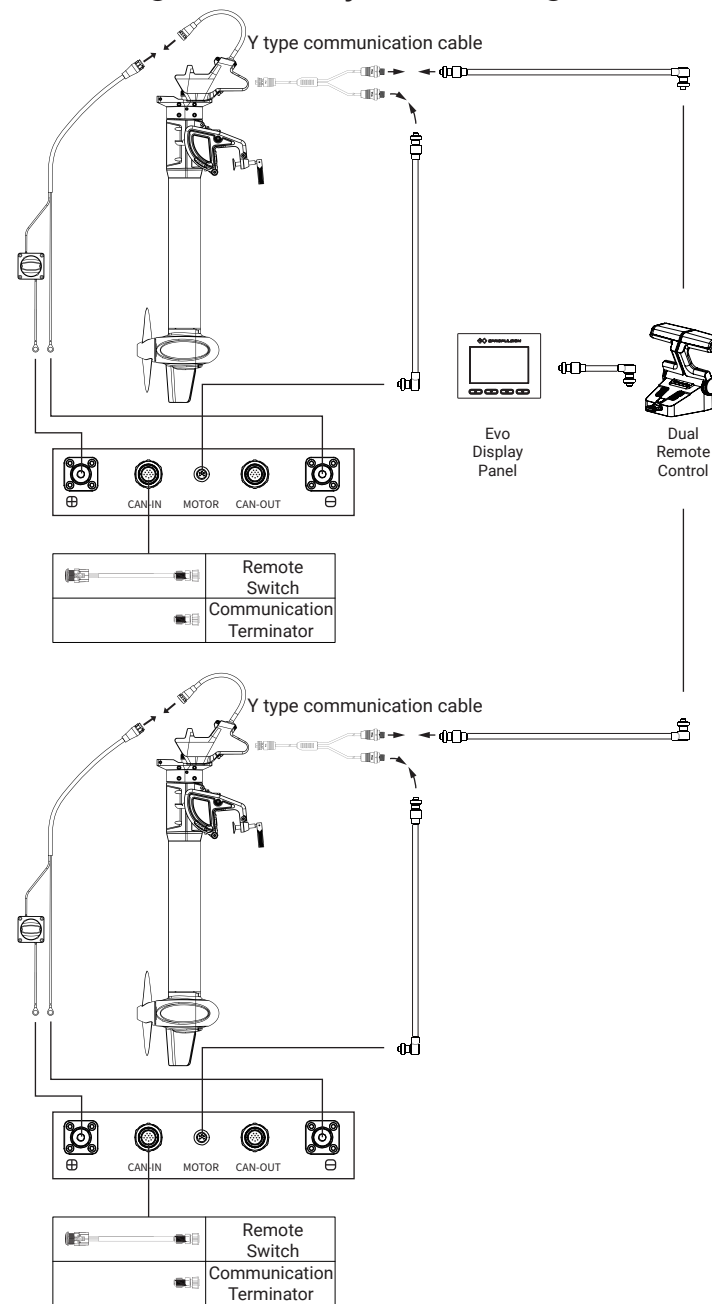

Figure 4-2

5 Operation

5.1 Checklist before Start

1. Check and ensure the battery has enough power.
2. Ensure the outboard is correctly and firmly installed on the boat.
3. Ensure the propeller is correctly and firmly installed on the outboard.
4. Ensure the battery is correctly and firmly installed on the outboard.
5. Before start, check and ensure the throttle is in zero position.
6. Ensure the throttle can travel smoothly.
7. Check the connections before each trip, ensure the connections are correct and secure, no disconnection or worn or aging connections.
8. Check and ensure the power port is dry to avoid short-circuit.

⚠ Only start the outboard when the propeller is under water.

⚠ If the cable has been immersed in water, please dry the cable thoroughly before connection or turning on power.

5.2 Starting

Step1: Put the kill switch on the proper position of tiller/remote control, and attach the other end of the kill switch to your wrist or life vest

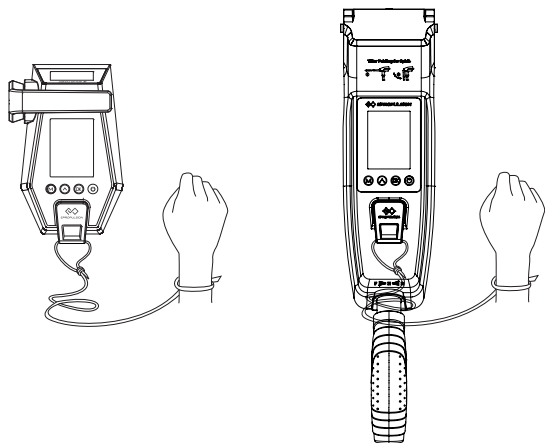

Figure 5-1

⚠ For safety consideration, please use the kill switch in the package, and always attach the lanyard of kill switch to your wrist or life vest, so that the outboard will be stopped in the emergency situation of falling.

⚠ The kill switch has magnetic field, keep it 50cm/20inch away from pacemakers and other medical implants.

⚠ The magnetic field of kill switch may interfere with some electronic instruments, keep it away from these electronic instruments.

⚠ Keep the kill switch 50cm/20inch away from magnetic cards (e.g. Credit cards) and other magnetic media.

Step2: Press and hold (≥ 2 secs) the "POWER" button to power on the system.

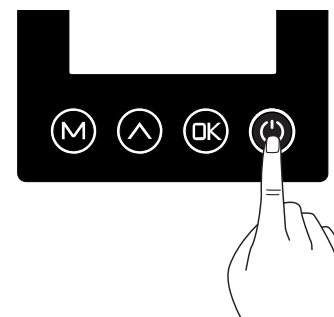

Figure 5-2

Step3: Turn the throttle from zero position to a desired direction to start the outboard motor. Change the heading direction of the boat by turning the tiller on horizontal level.

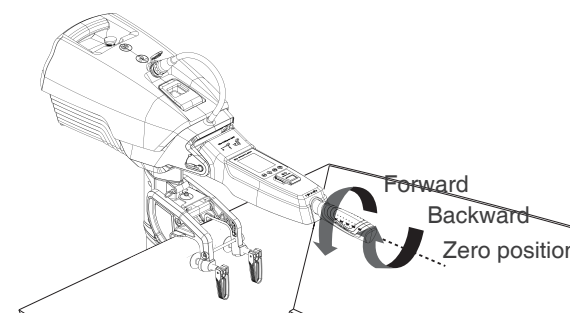

Figure 5-3

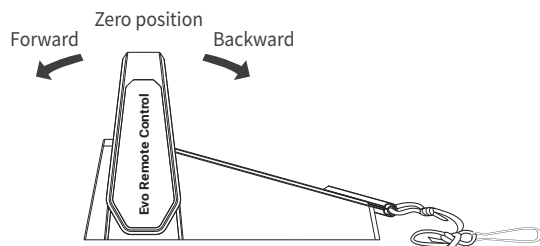
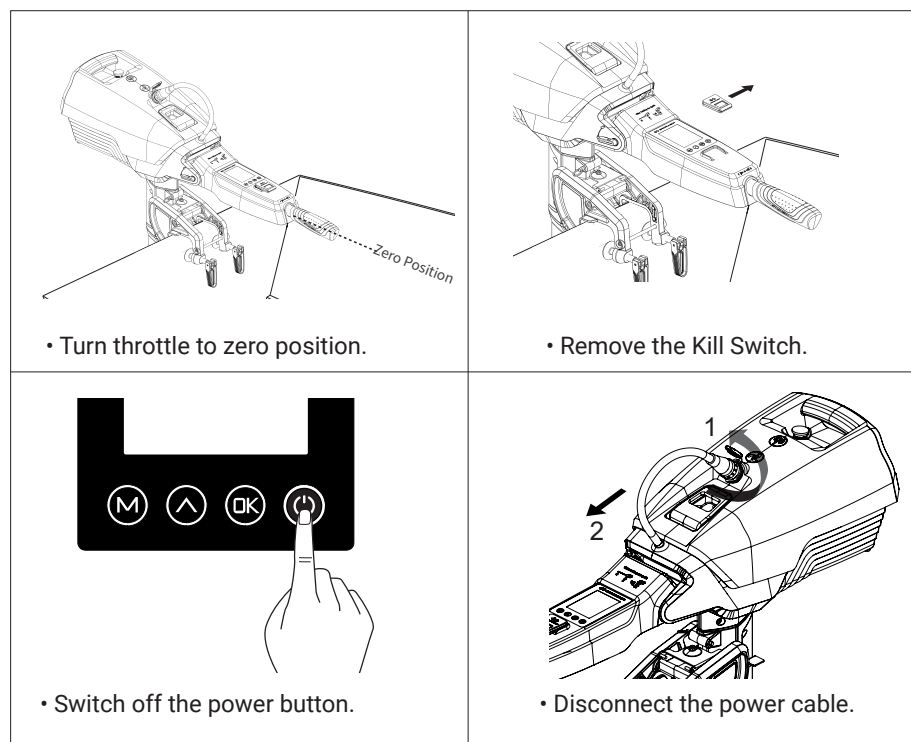

Figure 5-4

5.3 Stopping

The outboard can be stopped in one of the following four ways.



Do not use the tiller handle to tilt or lift your outboard. The damage of tiller or battery base due to pushing down the handle is out of warranty.

In normal operating procedure, it's recommended to stop the outboard as following steps.

1. Rotate/Pull the throttle to zero position.
2. Wait until the outboard stops, then remove the kill switch from tiller/remote control.
3. Press and hold (≥ 2 secs) the "POWER" button to power off the system.
4. Tilt the outboard out of water and uninstall it from boat according to your requirement.

In abnormal situations like a fall over emergency, it's recommended to stop the outboard motor by removing the kill switch from the tiller.

In malfunction situations, the outboard will stop immediately for protection. The outboard will stop if one of the following situations occurs.

1. The throttle is in zero position.
2. The power button is switched off.
3. The kill switch is removed.
4. The connection between tiller and battery is cut.
5. The battery is empty.
6. The outboard goes malfunctions (e.g. motor is blocked or the battery voltage drops below 33V).
7. Press the button of the safety wristband.
8. The safety wristband is disconnected.

It's recommended to tilt up the outboard out of water when the motor is not running.

5.4 Power off the External Battery

Please follow the steps below to power off the external battery.

1. Stop the outboard (refer to 5.3 Stopping).
2. Turn off the power switch.
3. Turn off the battery (if the battery has a switch), unplug the external battery cable.

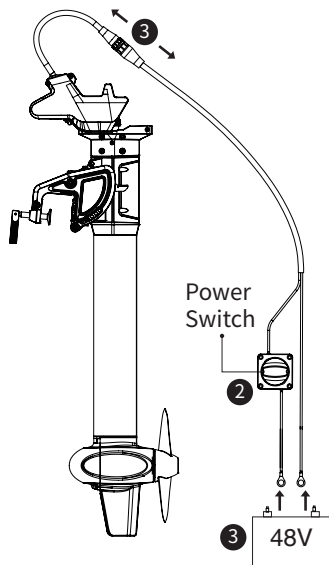

Figure 5-5

5.5 Tiller Adjustment

The Evo Tiller of SPIRIT 1.0 Evo is adjustable in both horizontal and vertical directions.

Pulling up the tiller

Pull up the tiller if necessary during operation.

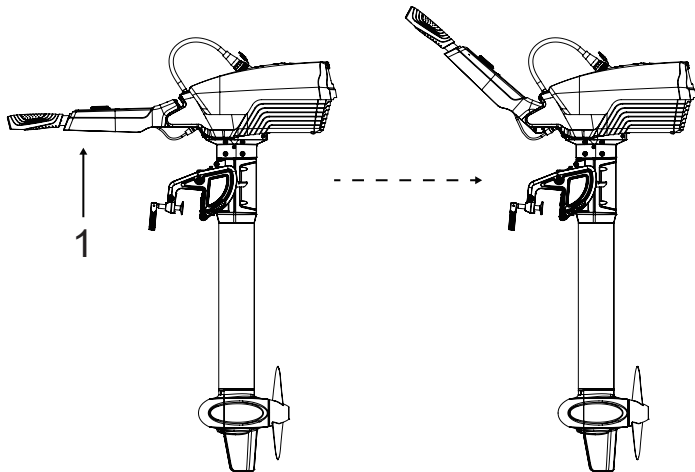

Figure 5-6

Folding the tiller

After rotating the clamping bracket by 90°, draw the tiller along axial direction to the limit then the tiller can be folded down.

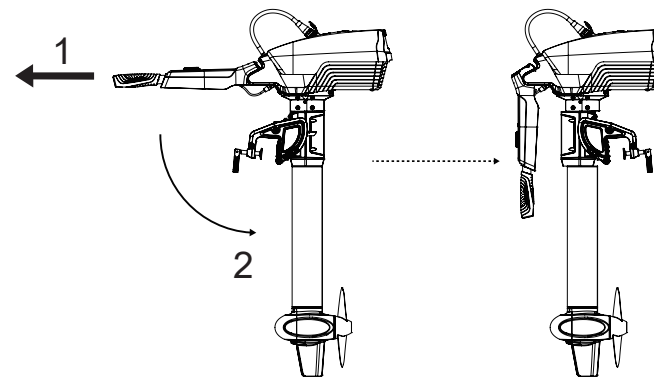

Figure 5-7

💡 Folding the tiller provides convenience when transporting or storing the outboard motor.

5.6 Tilting up the Outboard Motor

Toggle up the Trim Release Lever once, then take the battery handle to tilt up the outboard motor to a maximum height. After a “click” sound, release the battery handle and the outboard will stay at a position of 90° trim angle.

Hold the battery handle and toggle up the Trim Release Lever once again, users can lay down the outboard gently to the original position in water.

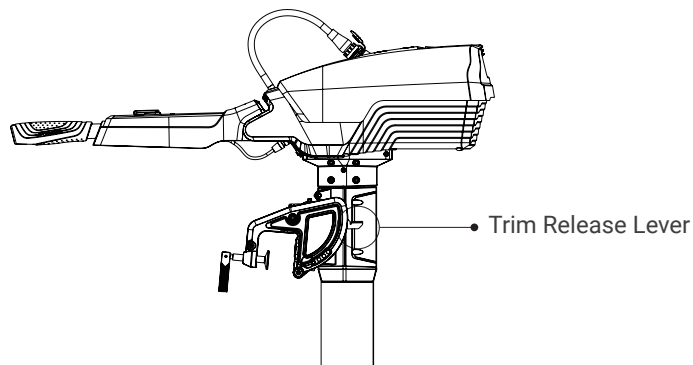

Figure 5-8

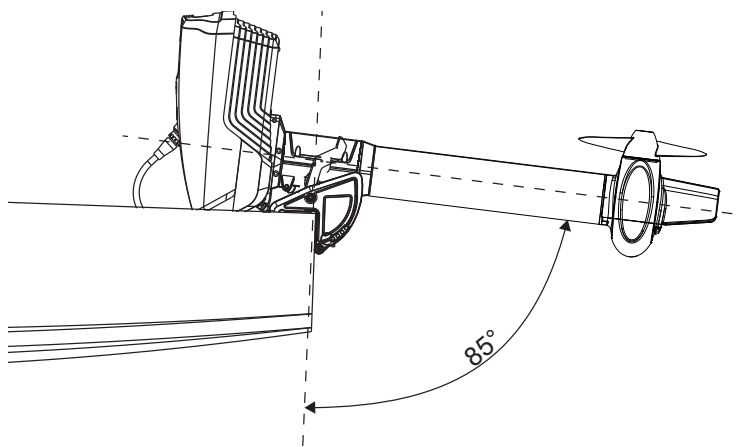

Figure 5-9

- ⚠ Never toggle the Trim Release Lever when the propeller is rotating.
- ⚠ Slight and gentle operations are recommended when tilting up and down.

5.7 Fixing the Steering Direction

Before attaching the battery, inserting the Steering Lock Pin into the hole indicated in Figure 5-10 can fix the steering direction, and the rotation of tiller on horizontal level will be disabled. Use the pin if necessary.

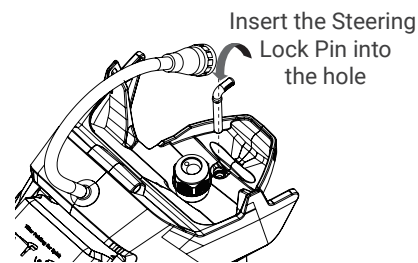

Figure 5-10

Steering direction fixed in front.

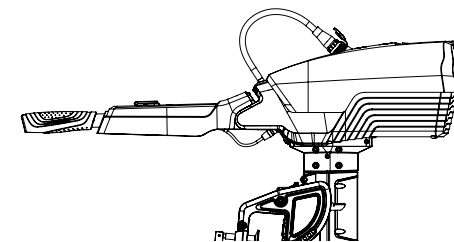

Figure 5-11

5.8 Fixing for Easy Carrying

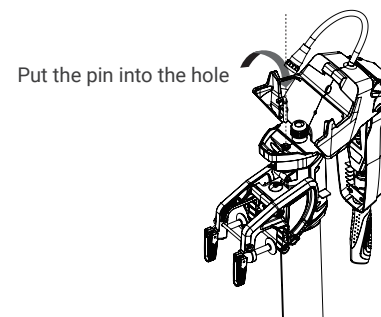

Figure 5-12

Rotate the tiller by 180° and fold to the position as indicated in Figure 5-12. Then put the lock pin into the hole to fix the folded tiller for easy carrying, storage or transportation.

6 Evo Control System

The Evo Control System is used for starting and stopping the outboard motor, adjusting the speed of the motor, configuring the battery parameters, displaying the system information and messages, etc. The Evo Remote Control is powered by either solar power or the built-in lithium battery, but the Evo Tiller is powered by connecting to the outboard with a communication cable. Evo Remote Control wirelessly or wiredly communicates with the outboard control system built in the main outboard motor, and Evo Tiller can only wiredly communicate with the outboard. The Evo Tiller itself owns the steering capability, while using the Evo Remote Control, it requires an additional steering wheel to help steer.

6.1 Display Panel

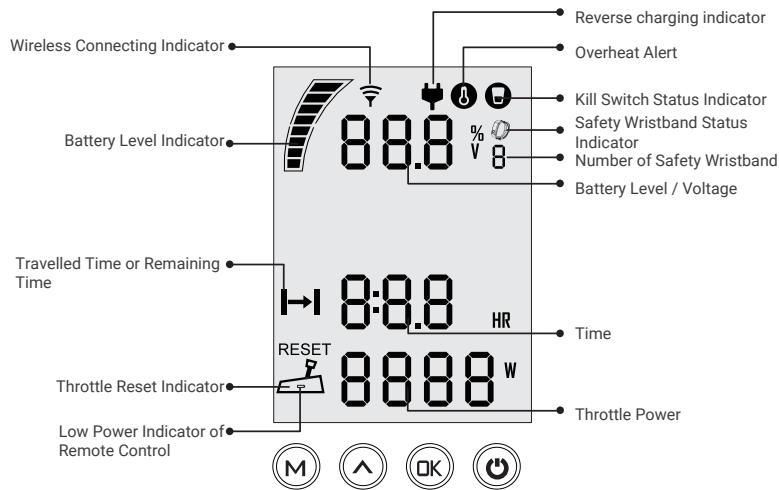



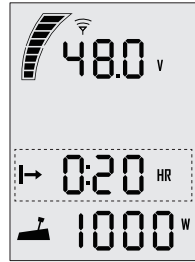
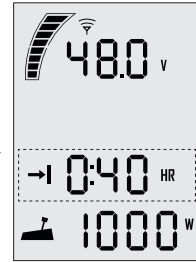

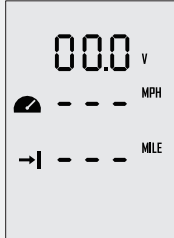
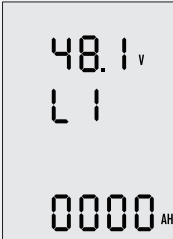







Figure 6-1















Buttons	Functions
 "Power"	<ol style="list-style-type: none"> 1. In power-off state, press and hold the power button to power on the control system. 2. In power-on state, press and hold the power button to power off the control system.

Buttons	Functions
 "OK"	<ol style="list-style-type: none"> 1. On setting pages, press "OK" button to save the current settings and switch to the next item. 2. On setting pages, press and hold "OK" button, and the system will save your settings, the display will exit from setting page and return to the home page. 3. If home page displays or all characters display on the page, press "OK" button and hold 5s to enter the pairing page. 4. On home page, press "OK" button to switch between voltage V and battery percentage %.
 "Up"	<ol style="list-style-type: none"> 1. On any setting page, press " ^ " button to view options for current setting. 2. In power-on state, when home page displays, press " ^ " button and hold 10s to enter the throttle calibration page. 3. On home page, press " ^ " button to switch the travelling distance or time displaying icon between " → " and " → ". <div style="display: flex; justify-content: space-around; align-items: center;"> <div style="text-align: center;">  Main page 1 </div> <div style="text-align: center;"> press "Up" button → </div> <div style="text-align: center;">  Main page 2 </div> </div>
 "Menu"	<ol style="list-style-type: none"> 1. In power-on state, press and hold " M " button to enter the preference setting page. <div style="text-align: center;">  Preference setting page </div>

Buttons	Functions
<p>M "Menu"</p>	<p>2. On preference setting page, press and hold "M" button to enter the battery setting page.</p> <div style="text-align: center;">  <p>Battery setting page</p> </div> <p>3. On any page, press "M" button to return home page.</p>

 If users enter the page without setting any parameters, the current parameters displayed on the page will be saved as user parameters by default.

Icons	Functions	
	Battery level indicator	Indicating approximate battery level. The solid blocks stand for remaining battery.
	Battery level/voltage	Indicating accurate current battery level percentage/battery voltage, is configurable in preference setting page. For example: 100 %: indicates current battery level. 48.0 v: indicates current battery voltage.
	Over-heat alert	<ul style="list-style-type: none">  Hidden: system temperature is in normal range.  Shown constantly: system is over temperature and the outboard will stop working. The outboard can't be started until the system temperature drops to a certain level.

Icons	Functions	
	Kill switch status indicator	<ul style="list-style-type: none">  Hidden: kill switch is present and is working well.  Shown constantly: the kill switch is detached.
	Time display	Displaying real time travel time. The time unit is HR (hour).
	Travelled time or remaining time	<ul style="list-style-type: none">  Remaining time that the outboard can travel.  Travelled time.
	Throttle Power	Displaying real time input power to the system. A blinking "RESET" indicating the throttle should be reset to zero position.
	Wireless connecting indicator	Displaying the control system is wireless connecting with outboard.
	Hydro generation indicator	<ul style="list-style-type: none">  Shown constantly: the hydro generation function is open.  Blink: the machine is charging the battery.
	Safety wristband connecting display	<ul style="list-style-type: none">  Shown constantly: the safety is connecting with the control system successfully.  Blink: there is a safety wristband to disconnect. <p>The number indicates the number of safety wristbands connected to the control system.</p>

6.2 Charging the Remote Control

The remote control has an in-built lithium battery for power supply. The battery will be charged automatically under normal use: get charged by solar power or wired connection.

6.2.1 Charging by Solar Power

When the solar panel receives enough sunshine, it will generate electricity to charge the in-built lithium battery.

 Face the solar panel of the remote control toward sunlight to get better charging effect.

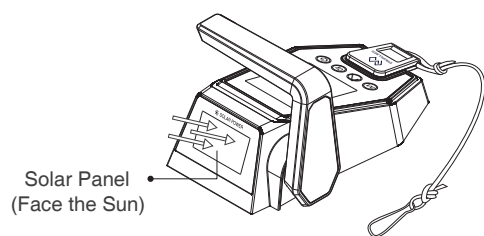



Figure 6-2

 Charging by solar power is recommended.

6.2.2 Charging by Wired Connection

If the remote control can't get enough solar power for a long time, the battery will run out. In this case, error code E60 (Figure 6-3) will display to remind you to charge the remote control.

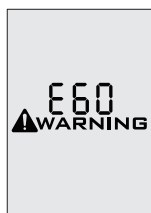

Figure 6-3

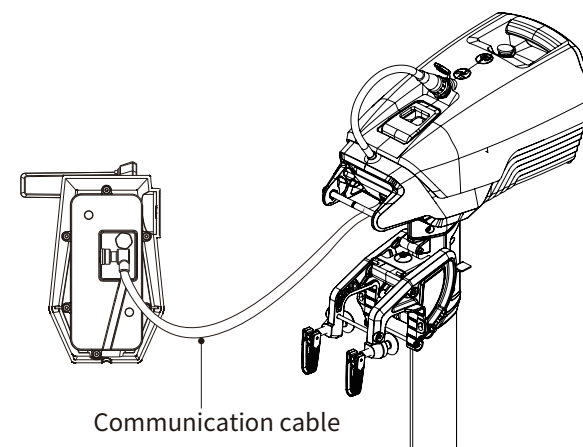







Figure 6-4

-  During long-term storage, ensure to charge the control system every 6 months to avoid over-discharge.
-  Do not short-circuit the main switch with other power supplies. The main switch should be mounted on the boat, and the back plate of the main switch should not be removed.
-  After long-term storage, charge the control system before use.
-  The communication cable is not included in this package. Please purchase one from your dealer if you choose this charging method.
-  Once the communication cable disconnects, charging automatically stops and the running motor stops. Please restart the motor.

6.3 Power Adjusting

6.3.1 Power Adjusting for Evo Control System

 Please place the safety switch on the Evo control system before operation.

The Evo Control system is mainly used to adjust the input power of the motor. When the battery is well connected and switched on, power on the control system to start the outboard, then slowly push/rotate the throttle forward position to increase the power. The maximum forward/backward power is shown below.

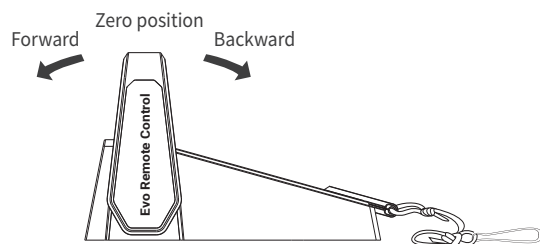

Figure 6-5

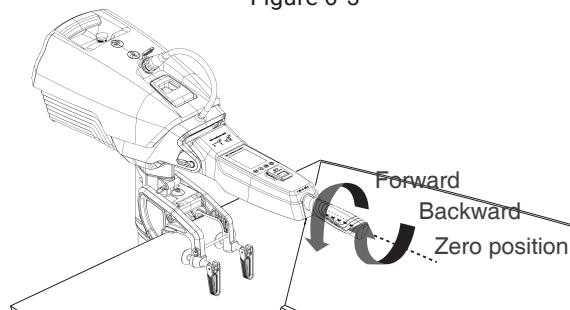





Figure 6-6

 Before power on the Control system, please reset the throttle to zero position.

 If you find a blinking "RESET" on the display panel, you are reminded to reset the throttle to zero position.

 If you pull the throttle from the forward position to the backward position directly, the motor will first stop shortly, then start turning to the reverse direction.

6.3.2 Recalibration

If the error code displays as the figure 6-7, users should calibrate the throttle **strictly** as below steps.





 Before calibration, please detach the kill switch from the control system.



Figure 6-7

Recalibration process	LCD Displaying
Step1: Long press "▲" button for 10s until "CAL FO" displays.	
Step2: Push the throttle to the maximum forward power position, then press "OK" button. "CAL St" will display and "CAL" will be blinking.	
Step3: Pull the throttle to the middle (zero) position where you can hear a click sound, then press "OK" button, "CAL bA" will display and "CAL" will be blinking.	
Step4: Pull the throttle to the maximum backward power position, then press "OK" button. It will return to the main page automatically.	

6.4 Use of Safety Wristband

6.4.1 Pairing Safety Wristband with Evo Control System

Press the “^” and “OK” buttons and hold for a while to display the safety wristband icon and “SE”. At this time, approach the safety wristband that needs to be paired, turn on the safety wristband, and the Evo control system displays the “SUC”, indicating successfully pairing. Keep in this page and continue to press “OK” to pair the safety wristband continuously (the maximum number of pairs is 8). After completing the pairing, press the “M” button to return to the main page.

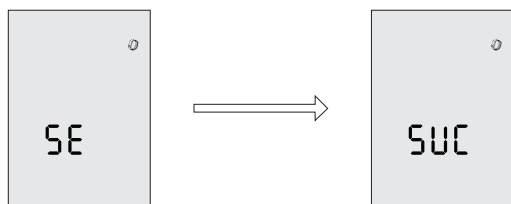



Figure 6-8

6.4.2 Man Overboard Protection

After the safety wristband and the Evo control system are paired, when the safety wristband falls into the water and the Evo control system is on, the outboard will stop immediately. The Evo control system display will flash with a buzzing sound. The safety wristband icon flashes and the number of safety wristbands decreases. At this time, you can continue to operate the machine by returning the throttle to zero position. The buzzer of the Evo control system will stop, but the display continues to flash. If you confirm that you need to cancel the alarm state, please restart the Evo control system or the disconnected wristband.

6.4.3 Emergency Stop

After the safety wristband and the Evo control system are paired, when the Evo control system is in operation, short press the button of the safety wristband, the outboard will stop immediately. The display of the Evo control system will flash with a buzzer. At the same time, the safety wristband icon flashes and the number of safety wristbands displayed at the bottom decreases. At this time, you can continue to operate the machine by returning the throttle to zero position. The buzzer of the Evo control system stops, but the display continues to flash. If you confirm that you need to cancel the alarm state, please restart the Evo control system or short press the safety wristband after 5 seconds.

 When a wristband is disconnected or an emergency stop is performed, the stop command of other wristbands will not work until it returns to the normal state.

6.5 Pairing Evo Control System with the Outboard

Before use please pair control system with the outboard. Evo Tiller will automatically pair with the outboard after mounting on the outboard properly. There are two methods to pair the remote control with the outboard. Please choose one of the two methods and follow the steps to build new communication.

Method 1. Pairing without Communication Cable

Step1: Switch off system power and hold the remote control within 0.5m of the outboard.

Step2: Press and hold the “⏻” button to switch on the remote control.

Step3: Ensure the wireless indicator is shown constantly on the home page.

Step4: Press “OK” button and hold 5s to enter the pairing setting page (Figure 6-9). On this page, you can find the blinking “Add” and “RUF”, and a countdown timer “060” (60s).



Figure 6-9

Step5: Switch on system power. Wait for them to get paired in seconds.

Step6: After pairing, the LCD panel will display as Figure 6-10 for 5s, then returning to home page automatically.

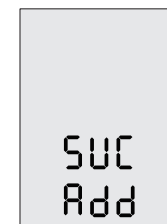



Figure 6-10

 If pairing fails within 60s, go back to **Step4** and try again.

Method 2. Pairing with Communication Cable

Step1: Switch off system power and the remote control.

Step2: Connect the remote control and the Communication module with a communication cable.

Step3: Switch on system power and the remote control. Wait for them to get paired in seconds. Pairing succeeds when home page displays.



No matter it is in wireless communication status or not, it will switch to wired communication status when you are pairing with a communication cable.



If the control system or the outboard is replaced with a new one, the original wireless link will break and wireless communication failure will occur. The main page of the LCD panel on the Control system will display as below. In this case, users should conduct pairing again.

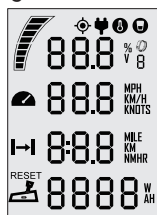

Figure 6-11

However, if the Control system and the outboard are not replaced, but the LCD panel still displays like this, you should check and:

- 1) Make sure the Control system is not far from the outboard motor;
- 2) Make sure all the equipment involved is normally powered on.

If the Control system still displays like Figure 6-11 after check, it indicates an error has occurred. Please contact your dealer for repair.

6.6 Hydro Generation Function

SPIRIT 1.0 Evo outboard can drive the propeller to charge the battery (only the ePropulsion battery) through water flow.

The machine will enter the hydro generation state if the following conditions are met:

1. Make the motor is under the water and the propeller works well.
2. The Evo control system is set to turn on the hydro generation function (enabled by default).
3. The Evo control system is in the zero position.
4. The ePropulsion battery power is below 90%.
5. The machine will enter the hydro generation state after the boat speed is above 6km/h stable for 4 seconds.
6. The hydro generation function can be used only when connecting ePropulsion batteries.
7. If using E-series battery or NAVY battery, please connect with a communication cable.

When any of the following conditions occur, the hydro generation will be stopped:

1. The Evo control system is set to turn off the hydro generation function.
2. The Evo control system is in the forward / backward state (not in the zero position).
3. The ship is not traveling or traveling too fast (higher than 35km/h).
4. The battery level is higher than 90%.

Set up the hydro generation function

When the Evo control system and the machine are successfully connected, and the Evo control system and the outboard are both on. Press the "M", "▲" and "OK" buttons at the same time to enter the hydro generation setting page. Then press "OK" to change the state of the hydro generation function (En means on, Dis means off).

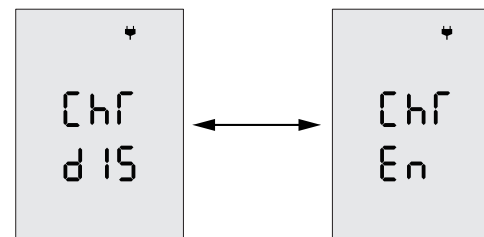

Figure 6-12

6.7 Warning Messages

When the outboard motor is running in abnormal conditions or out of order, a warning message with an error code will display on the LCD panel. Figure 6-13 is an example.

Please find more error codes and corresponding solutions in the below table.



Figure 6-13

Code	Cause	Solution
E01	Battery voltage beyond operation range.	Replace a battery based on suggested operation specifications. If the problem still exists, contact your dealer for repairing.
E02	Propeller may be blocked, causing motor overcurrent	Refer to Solution to E10.
	Motor fails or circuit board fails causing motor overcurrent	Try to turn off the main switch and wait for 10 seconds then turn on the switch again.
E06	The battery voltage level is too low.	Operate the motor at low power. Please charge the battery as soon as possible.
E10	Motor stall, which may be caused by blocked propeller	Turn off power, then clean up the things winding around the propeller. Test if the propeller can be rotated by hand before operation.
E11	The temperature of motor is too high.	Stop operating the outboard and wait until the temperature falls within the normal operating temperature range.

Code	Cause	Solution
E12	The temperature of circuit board is too high.	Stop operating the outboard and wait until the temperature falls within the normal operating temperature range.
E22	MCU Communication Abnormality	Please restart to see if the error disappears, if not, please contact your dealer for help.
E30	Throttle position sensor failure, should recalibrate the throttle position sensor.	Please refer to section 6.3.2 <i>Recalibration</i> to recalibrate the throttle position sensor.
E56	Communication Error between outboard and battery	Check if the communication cable between outboard and battery is well connected, if yes, please restart the system.
E60	The remote control is running out of power.	Please connect the remote control to the outboard by a communication cable. Please refer to section 6.2.2 <i>Charged by Wired Connection</i> .
All characters display	The motor has no power.	Connect the battery to the outboard and then turn on the main switch.
	Not paired	Please refer to section 6.6 <i>Pairing Control System with the Outboard</i> .

 If the problem persists, please consult your ePropulsion authorized dealer for assistance.

7 Battery Charging

Charge the battery when the state of battery level is low or empty. It's recommended to charge the battery after detaching it from the outboard though it's allowed to operate and charge the outboard simultaneously.

Step1: Power off the outboard first. Then disconnect the power cable and detach from the power port. Hold the handle and pull up the battery lock to detach the battery.

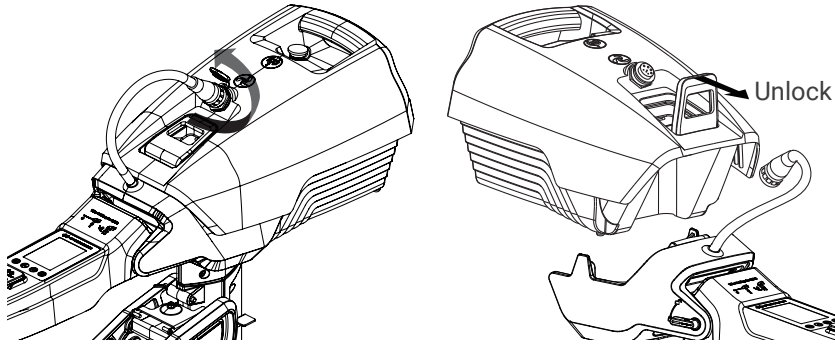

Figure 7-1

Figure 7-2

Step2: Connect the output cable of battery charger to the battery, then connect the AC power plug of the charger to the 100V~240V wall outlet.

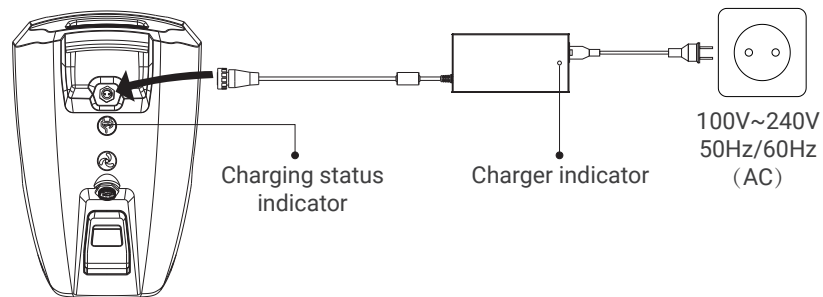

Figure 7-3

Indicator	Normal Status	Description
Charger indicator	Solid red light	The charger has been plugged into the charging port of the battery and it works well.
	Solid green light	The charger works well but has not been plugged into the charging port of the battery, or the battery has been fully charged.
Charging status indicator	Solid red light	The battery is being charged.
	Solid blue light	The battery has been fully charged.

Indicator	Abnormal Status	Description
Charger indicator	Light out	<ol style="list-style-type: none"> 1. Make sure the AC socket has power output. 2. Disconnect the battery with charger, if the charger indicator becomes solid green, there may be a fault in battery, please contact your dealer to change the battery. 3. If the charger indicator is still off after disconnecting with the battery, there may be a fault in charger, please contact your dealer.
Charging status indicator	Light out	<ol style="list-style-type: none"> 1. Make sure the AC socket has power output. 2. Disconnect the battery with charger, if the charger indicator becomes solid green, there may be a fault in battery, please contact your dealer to change the battery. 3. If the charger indicator is still off after disconnecting with the battery, there may be a fault in charger, please contact your dealer. After fixing the issues of the charger, please recheck the status of charging indicator. If there are still problems with battery, please contact your dealer.

Step3: Plug the battery charger out of the wall socket after the battery has been fully charged, then disconnect the battery charger port and charger.

8 Trim Angle Adjusting

SPIRIT 1.0 Evo has four trim angle options including 21°, 14°, 7° and 0°. The trim angle should be adjusted according to the boat type and the running speed to achieve higher efficiency. It is recommended to try different trim angles at your desired running speed to achieve the best performance.

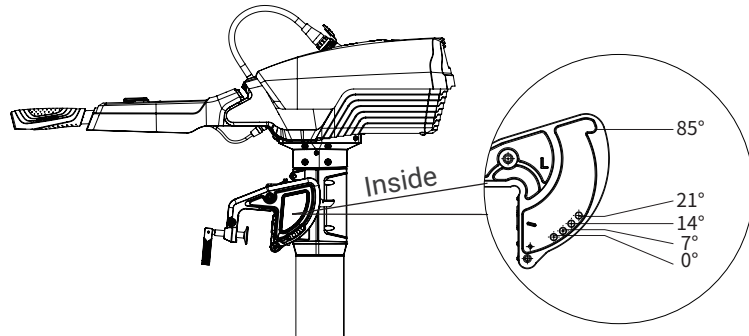

Figure 8-1

⚠ Only adjust the trim angle when the outboard is stopped.

⚠ Never toggle the Trim Release Lever if the propeller is rotating.

To adjust trim angle

Step1: Pull the trim release lever up and tilt up the outboard to the 85° position. (Users can refer to the *section 5.6 Tilting up the Outboard Motor.*)

Step2: Remove the pull ring on the trim pin and then pull the trim pin out.

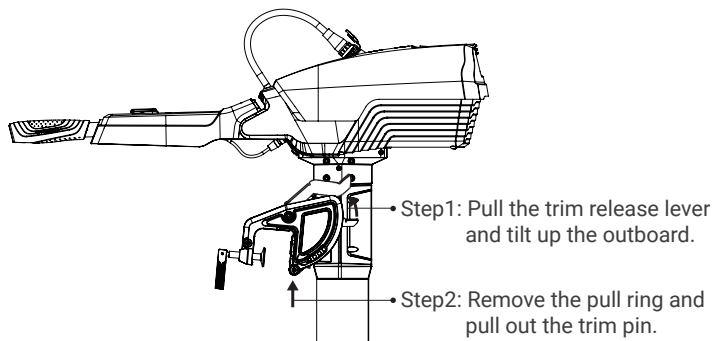

Figure 8-2

Step3: Select a desired trim angle and insert the trim pin into the corresponding position, attach the pull ring to fix the trim pin.

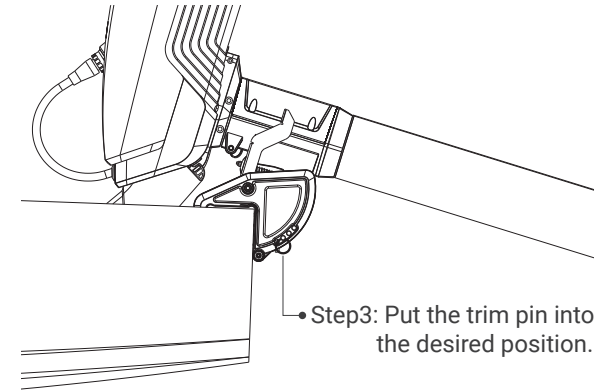

Figure 8-3

Step4: Pull the trim release lever again to lay down the outboard motor, and the outboard motor will stay at the desired trim angle.

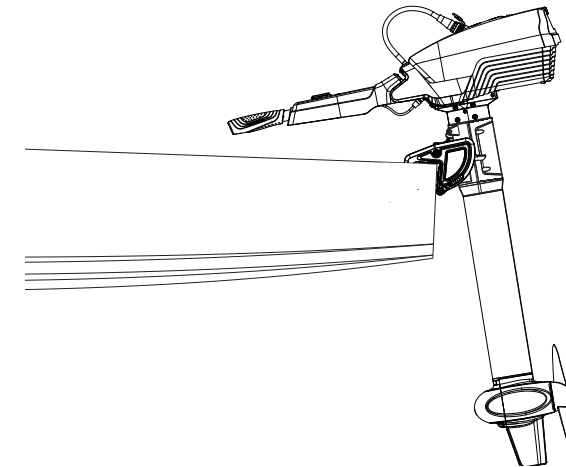

Figure 8-4

Step5: Try to tilt up the outboard and test if the angle is successfully fixed. It is recommended to try different trim angles to help find the best working trim angle for the boat and operating conditions. Please increase the speed gradually during test, watch out for water cavity and other instability problems, if the problem gets serious, stop the outboard immediately and try to reduce the trim angle.

9 Anti-grounding Mode

When the boat runs in shallow water or in complicated underwater conditions, it may meet grounding dangers. Setting the outboard to anti-grounding mode will protect the outboard motor from damage if the outboard hits submerged reefs or rocks. In anti-grounding mode, the underwater part of the outboard is flexible in tilting direction and the motor will automatically tilt up if it hits something underwater.

⚠ Never turn the throttle backward when the outboard is in anti-grounding mode.

To set the outboard in anti-grounding mode:

Step1: Pull the beaching pin to the limit and hold, then pull the trim release lever to the upmost position.

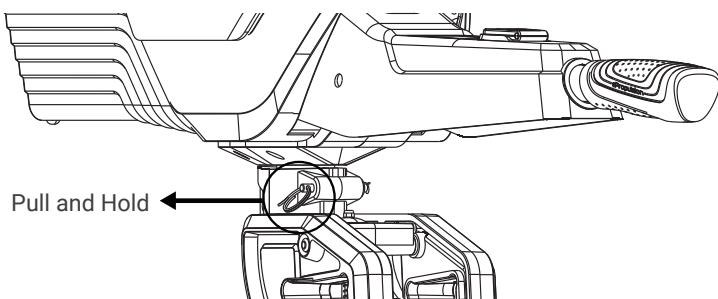

Figure 9-1

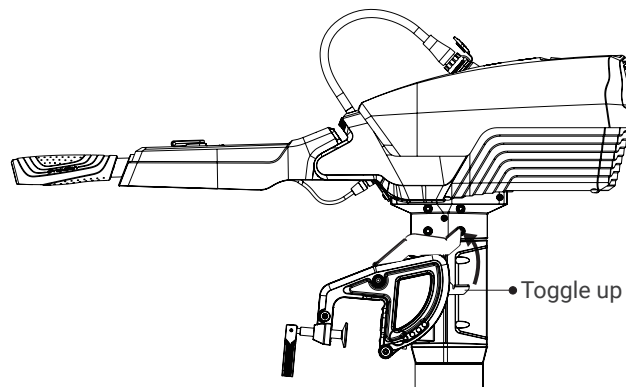

Figure 9-2

Step2: Release the beaching pin and the trim release lever will stay at the position shown in the figure below. And then the anti-grounding mode is activated.

To inactivate the anti-grounding mode

Pull the beaching pin again and make the trim release lever return to horizontal position, the anti-grounding protection will be disabled and the outboard will work in normal state.

⚠ Never pull the trim release lever when the propeller is rotating.

⚠ Never activate the anti-grounding mode when the propeller is rotating.

⚠ Only use the anti-grounding mode in necessary conditions, such as in shallow water, near the shore or unknown underwater conditions.

10 Maintenance

10.1 Notes

Regular maintenance is beneficial to keep your outboard working in optimal condition.

Do not start the outboard in shallow or unknown water conditions. Only use the outboard in deep water area.

In order to clean and reduce corrosion, use fresh water to wash the whole outboard after use in salt water.

⚠ Regularly check whether the propeller is damaged, whether there is a fishing line entangled. The motor is out of warranty due to the fishing line causing water to enter the motor.

⚠ Disconnect the battery from outboard before maintenance.

⚠ Conduct the maintenance under instructions of professional experts or your dealer.

⚠ Only use ePropulsion original components for replacement and maintenance.

10.2 Propeller Maintenance

⚠ Ensure the battery is disconnected before each check, as a rotating propeller is dangerous.

⚠ Gloves are recommended to wear, in order to protect your hand from the sharp propeller edges.

Check the propeller based on the following tips, then refer to the figure 12-1 to replace a new propeller if necessary.

1. Check the propeller blades for wear broken and other damage.
2. Check the pin for wear and damage.
3. Check for water plants, fishing net or line twine around the propeller.

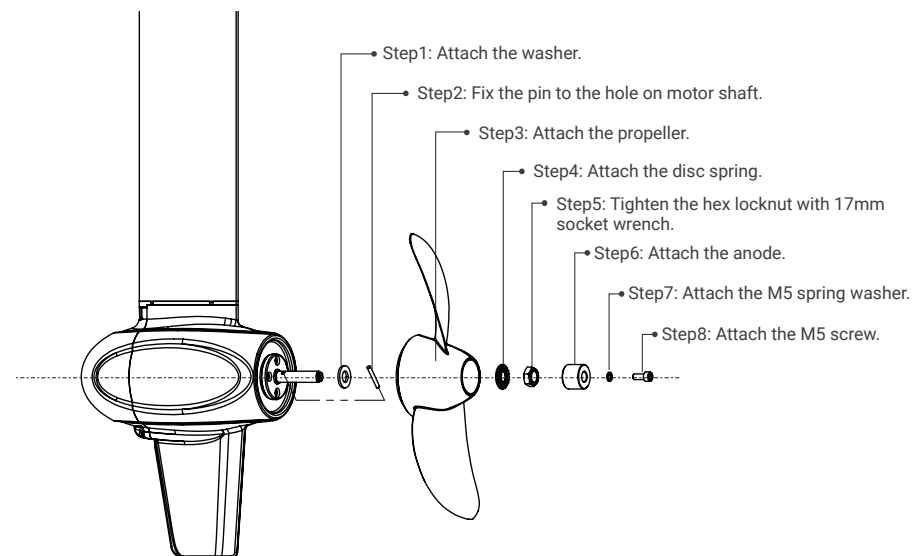

Figure 10-1

10.3 Replacing the Anode

Please refer to the figure below to replace a new anode if necessary.

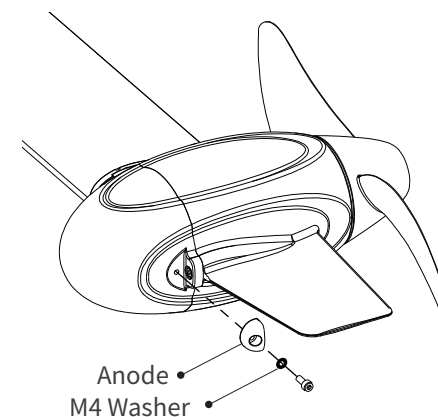

Figure 10-2

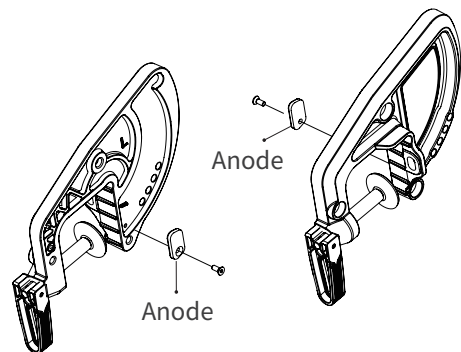

Figure 10-3

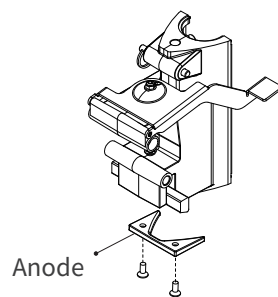

Figure 10-4

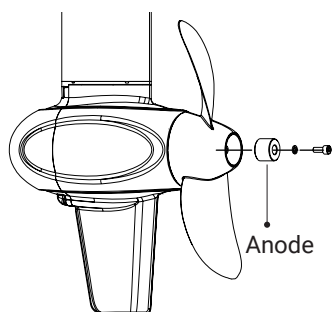

Figure 10-5

10.4 Maintenance of Electrical Contacts

Clean all electrical contacts with electrical contacts cleaner every two months, and clean immediately once there is rusty show up.

10.5 Maintenance Time Table

Regularly maintained in proper manner and used in normal condition, the outboard can work at its optimal state. The following table shows a general maintenance frequency, which however may vary according to operating conditions.

Item	Operations	Initial	Every	
		50 hours (3 months)	100 hours (6 months)	200 hours (12 months)
Anode	Check/Replace	□	□	■
Greasing points	Greasing		□	■
Propeller and pin	Check/Replace	□	□	■

💡 The "□" symbol indicates checks may be carried out by users. The "■" symbol indicates work to be carried out by your dealer.

Greasing Map

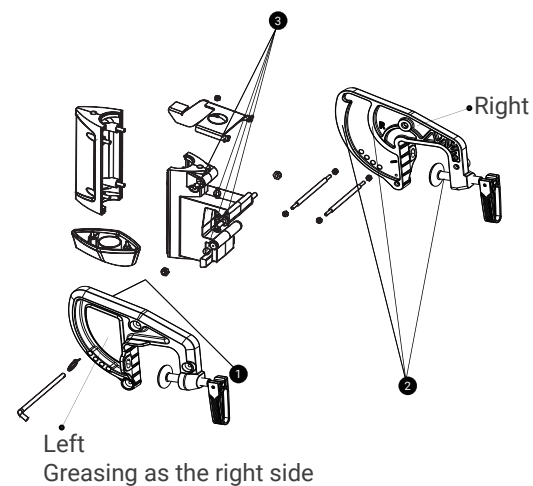

11 Transportation and Storage

11.1 Transportation

For long distance transport, please use the ePropulsion original package to pack the outboard before transportation.

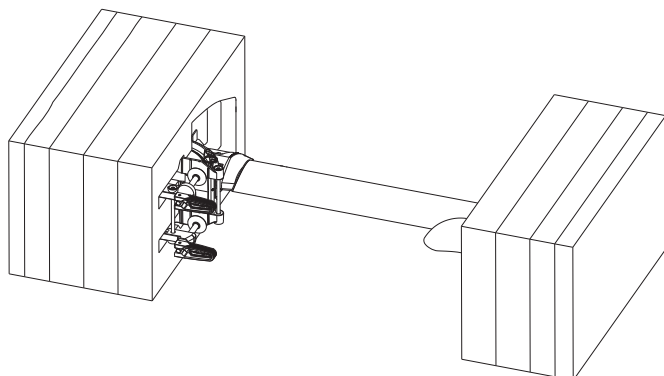

Figure 11-1

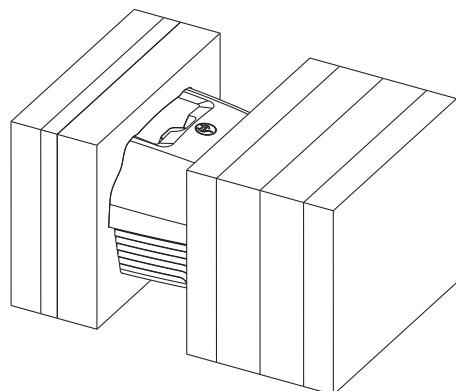

Figure 11-2

⚠ The Li-ion batteries higher than 100Wh are not allowed in the aircraft. The Li-ion batteries are classified under Class 9 (dangerous goods - see *Lithium Battery Guidance Document IATA 2015 Revision 1 – I-Site www.iata.org*).

⚠ Never ship a damaged or broken battery.

11.2 Placement

When placing the outboard on the ground, ensure the ground is flat and clean. It's better to put some damping cotton or cushion under the outboard to prevent damage.

11.3 Storage

If your outboard is going to be stored for more than 2 months, it's advised to have the outboard cleaned, checked prior to storage. It's recommended to pack the outboard with ePropulsion original package for storage.

⚠ Take adequate damping-absorber for protection before transport and storage. And ensure the propeller receives no pressure if the propeller is installed on the propeller shaft.

⚠ Store the outboard in a dry, well ventilated place without direct sun exposure.

11.4 Disposal and environment



All products bearing this symbol are waste electrical and electronic equipment (WEEE as in directive 2012/19/EU) which should not be mixed with unsorted household waste. Instead, you should protect human health and the environment by handing over your waste equipment to a designated collection point for the recycling of waste electrical and electronic equipment, appointed by the government or local authorities. Correct disposal and recycling will help prevent potential negative consequences to the environment and human health. Please contact the installer or local authorities for more information about the location as well as terms and conditions of such collection points.

12 Emergency Situations

12.1 Impact Damage

If the outboard strikes some object in the water, please follow the procedures below.

1. Stop the outboard immediately.
2. Check the propeller and other components before you start the motor again.
3. Return to the nearest harbor or beach.
4. If the motor is damaged, find your dealer or ePropulsion service center for help.

12.2 Submerged Outboard

If the outboard is submerged, stop it immediately and disconnect the battery. Ensure the outboard is thoroughly inspected before re-operation. Please contact your dealer for more information.

12.3 Low Battery Level

When the battery voltage is lower than a set threshold, the outboard will stop automatically to prevent battery from over-discharging. If this happens when the outboard is far away from the shore, and no new battery can be replaced, it's recommended to wait until the battery voltage recovers, and you can restart the outboard to return with throttle power under 100W.

13 Warranty

Guangdong ePropulsion Technology Co., Ltd. ("ePropulsion"), China, warrants its products to be free of defects in material and workmanship under normal usage with proper installation and routine maintenance for a period of thirty-six (36) months from date of delivery of products to end customers (the "Limited Warranty Period"). The Limited Warranty is provided to the first end customer of ePropulsion products ONLY. The Customer is entitled to free repair or replacement of defective or non-conform parts. Any warranty claim must be made within six (6) months of discovery of issues as provided below.

If the Limited Warranty Period expires, you can still enjoy maintenance services from dealers/distributors authorized by ePropulsion (the "ePropulsion Service Partners") with minimum maintenance charge per occurrence.

In all warranty cases, ePropulsion will only bear the repair cost and other costs (such as those related to product installation, disassemble, transportation, financing, rental, etc.) as a direct result of issues covered by the Limited Warranty only. Any costs irrelevant to or out of the scope of the Limited Warranty will be born by the Customer alone.

Beyond the Limited Warranty, the Customer may have statutory rights in your jurisdiction according to applicable laws. Nothing in this Limited Warranty affects such rights. The Customer may have warranty claim rights arising from the purchase contract with ePropulsion Service Partners in addition to the rights granted by this Limited Warranty.

Products for commercial/professional use, even if only temporarily, are not covered by the Limited Warranty. Instead, the statutory warranty in your jurisdiction shall apply. You are encouraged to consult with ePropulsion Service Partners for applicable warranty and advice before engaging in such use.

*** Commercial/professional Use refers to application cases that have high use frequency, high-reliability requirement or aim for money making, etc.**

To keep your warranty valid, you shall follow:

- Keep the product label intact and record the Serial Number shown on the label. Never tear the label off the product. A product without the original product label is not covered by the Limited Warranty provided by ePropulsion;
- The Limited Warranty is not transferable and will not be reissued;

- The Limited Warranty may change from time to time. Pls visit our website (<http://www.epropulsion.com>) for the latest version.

Out of Warranty

ePropulsion may refuse a warranty claim if:

- Any improper operation contradicts what is written in the user manual;
- Accident, misuse, dropping, improper care or storage, willful abuse, physical damage, overcharging, over discharging, or unauthorized repair;
- Water ingress caused by external sources such as fishing nets, submerging underwater, etc;
- Product modification, alternation, disassembly, or parts/accessories attachment, which are not expressly permitted or recommended by ePropulsion;
- Failure of, or damage caused by, any 3rd party products;
- Consumables are out of warranty scope (like propeller, anode, etc.);
- Purchases of product from unauthorized dealers or seller;
- Normal wear and tear and routine servicing are excluded from the warranty;
- The product gets further damaged due to improper packing during delivery. The further damaged part will be deemed as out of warranty coverage;
- Lithium battery is classified as a UN9 hazardous item, posting and packing must be in accordance with the relevant law of the local country directive. Non-compliance may result in out of warranty coverage.

Limited Warranty Claim Procedures

The Customer shall follow the warranty claim process to make a Limited Warranty claim:

1. Contact your nearest ePropulsion Service Partners and they will provide further instruction to you if such defects are covered by the Limited Warranty or theirs.
2. Send the defective product to them together with Proof of 1st-time Purchase (e.g., receipt, invoice, etc., with information of product purchased and date of purchase), the Confirmation of Online Warranty Registration, ex-factory Serial Number, etc. Note that all labels shall be kept intact. The warranty is valid only when the information above is correct, genuine, and complete;
3. Make sure the product is properly packed during delivery, the original package is highly recommended.

4. The ePropulsion Service Partners will conduct diagnosis and examination on the defective products to check the validity of the warranty claim.
5. If your warranty claim is accepted, the Product or its defective components/parts will be either repaired or replaced free of charge. Note that any delivery cost incurred in the process shall be bearded by you.
6. In case your warranty claim be rejected, a repair/replace cost and fee with round trip delivery cost will be estimated and sent to you for confirmation. ePropulsion Service Partners will only begin the work after your written confirmation.